

Umgebungswahrnehmung und Verhaltensplanung für Kognitive Roboter

Sven Behnke

Universität Bonn

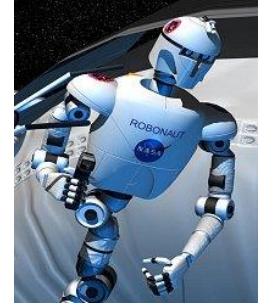
Institut für Informatik VI

Autonome Intelligente Systeme



Neue Anwendungsgebiete für Roboter

- Autonomes Fahren
- Logistik
- Landwirtschaft
- Kollaborative Produktion
- Alltagsassistentz
- Weltraum, Suche&Rettung
- Medizin, Pflege
- Spielzeuge
- **Brauchen mehr Kognition!**



Einige unserer Kognitiven Roboter

- Ausgestattet mit zahlreichen Sensoren und Gelenken
- Demonstration in komplexen Szenarien



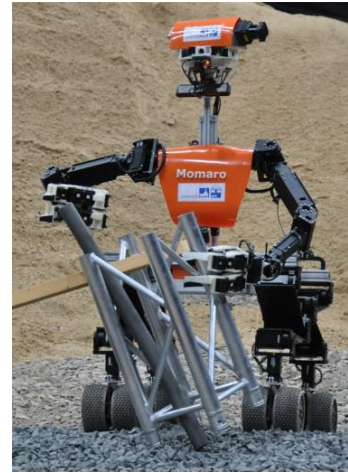
Fußball



Serviceaufgaben



Griff in die Kiste



Mobile Manipulation



Inventur

RoboCup 2016 TeenSize-Finale



Visuelle Wahrnehmung der Spielsituation



RoboCup 2017 AdultSize-Finale

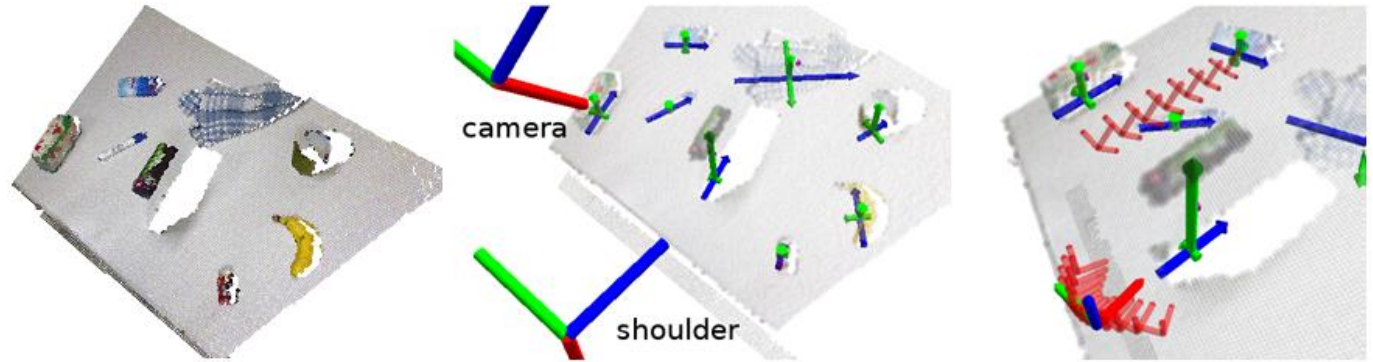


Kognitiver Serviceroboter Cosero

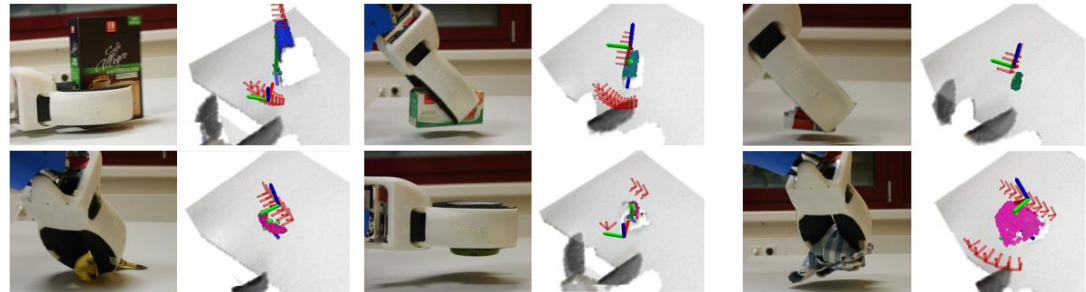


Table-top Analysis and Grasp Planning

- Detection of clusters above horizontal plane
- Two grasps (top, side)



- Flexible grasping of many unknown objects

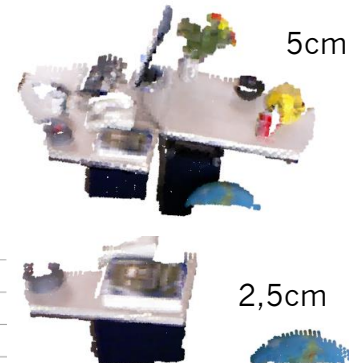
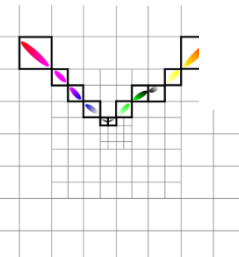
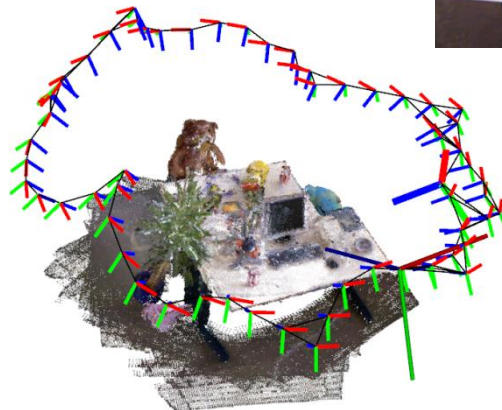


[Stückler et al, Robotics and Autonomous Systems, 2013]

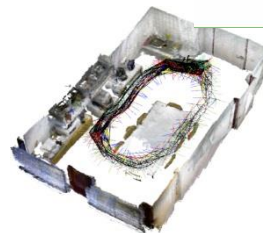
3D Mapping by RGB-D SLAM

[Stückler, Behnke:
Journal of Visual Communication
and Image Representation 2013]

- Modelling of shape and color distributions in voxels
- Local multiresolution
- Efficient registration of views on CPU
- Global optimization



- Multi-camera SLAM

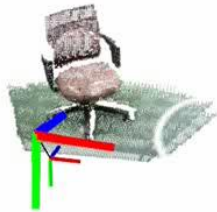


[Stoucken]



Learning and Tracking Object Models

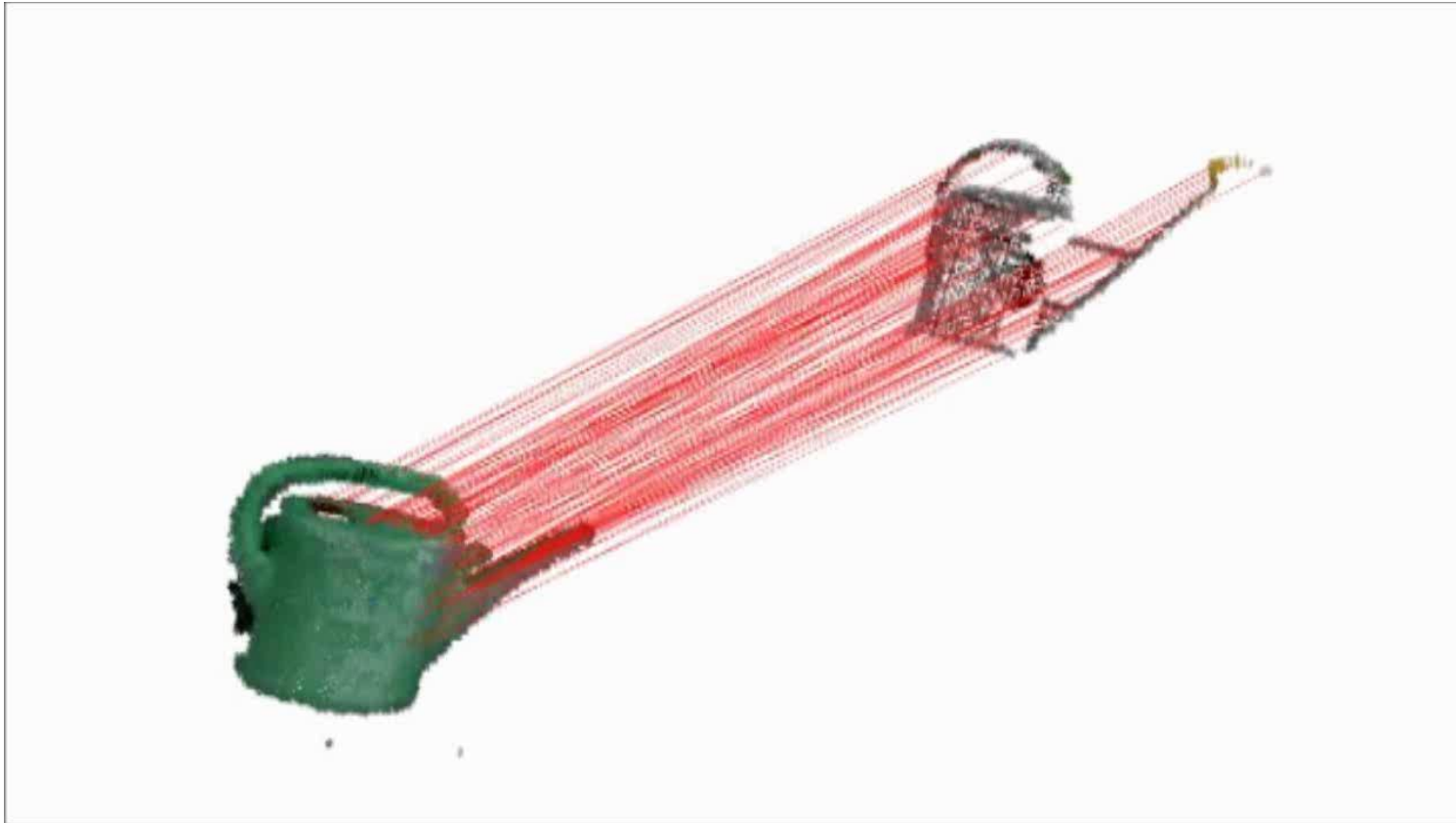
- Modeling of objects by RGB-D-SLAM



- Real-time registration with current RGB-D frame



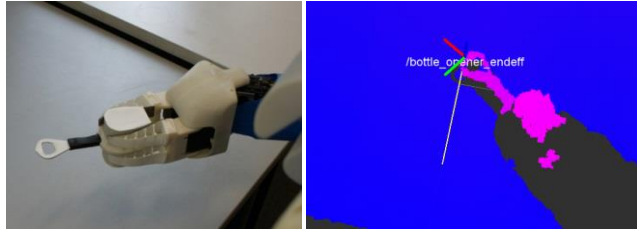
Grasp & Motion Skill Transfer



[Stückler,
Behnke,
ICRA2014]

Tool use: Bottle Opener

- Tool tip perception



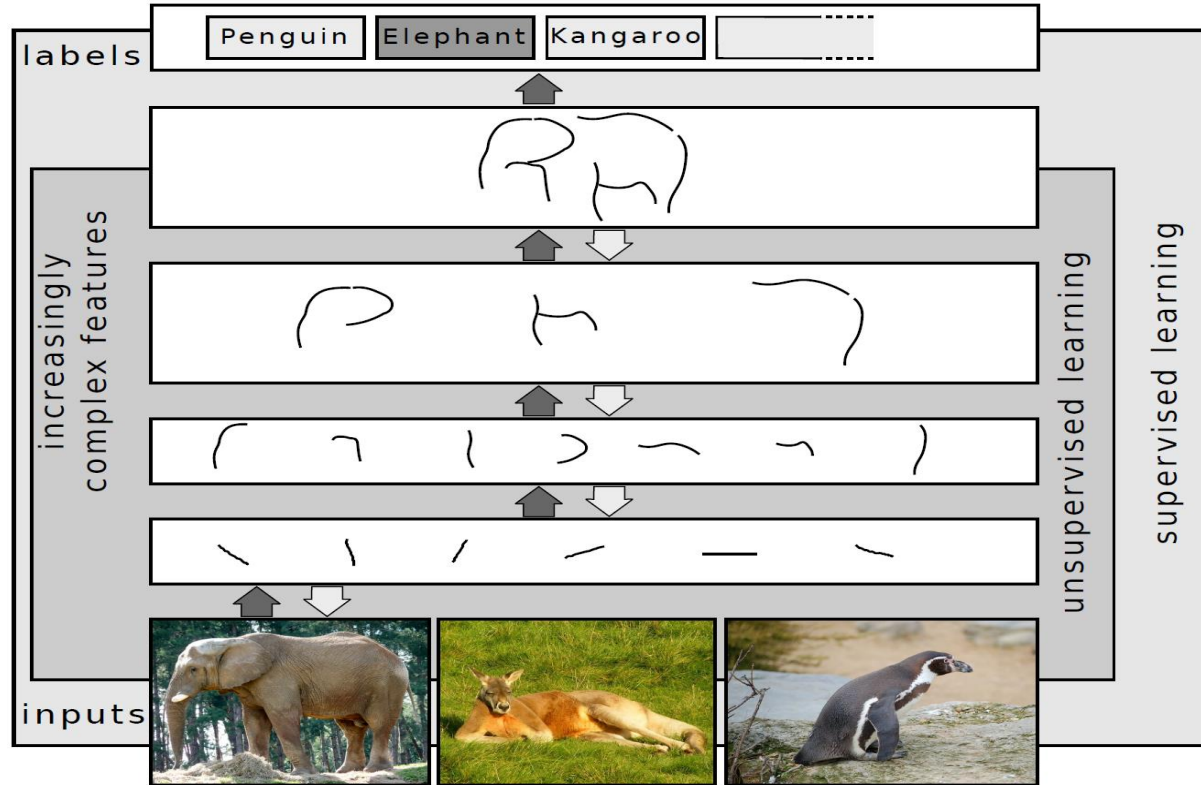
- Extension of arm kinematics
- Perception of crown cap
- Motion adaptation



[Stückler, Behnke, Humanoids 2014]

Deep Learning

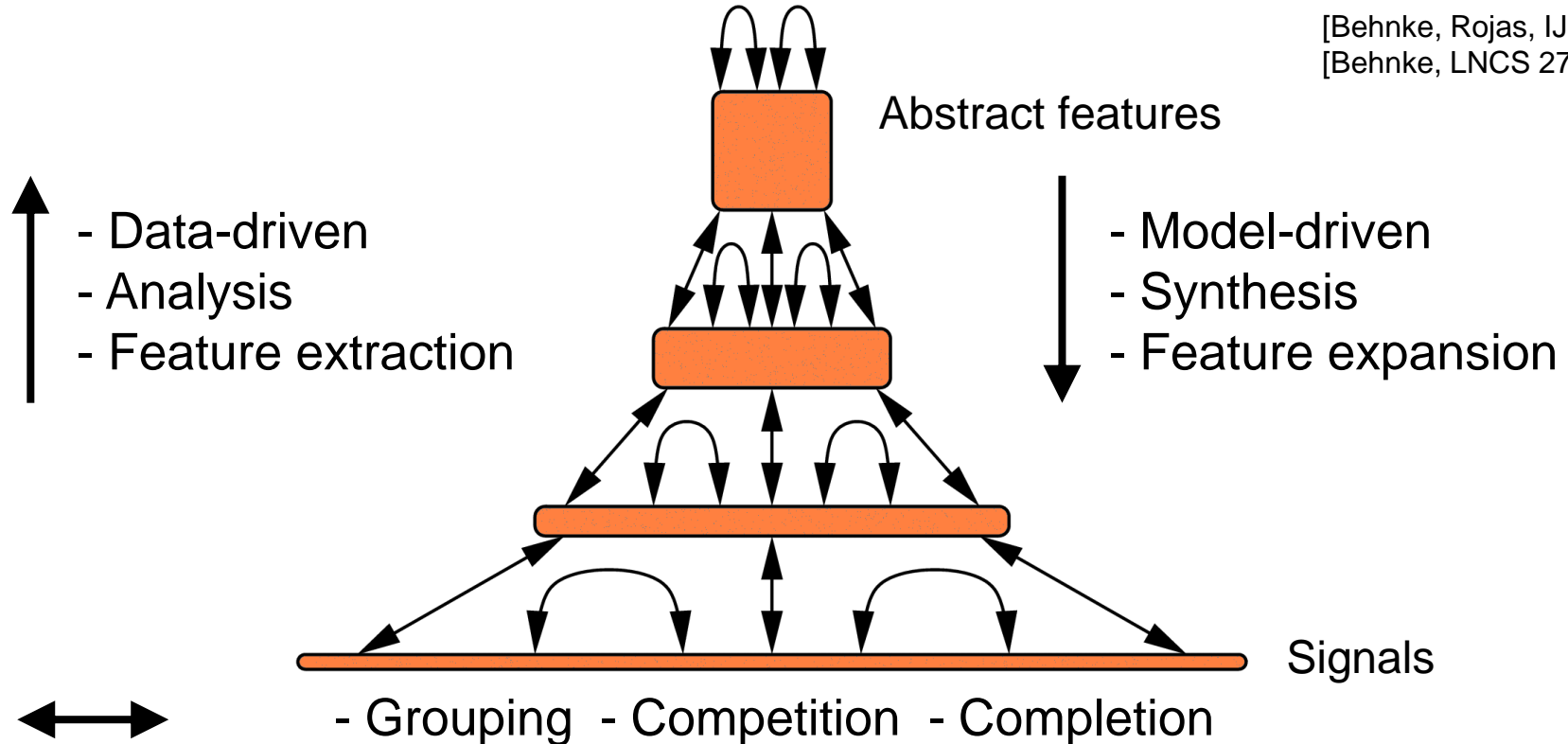
- Learning layered representations



[Schulz;
Behnke,
KI 2012]

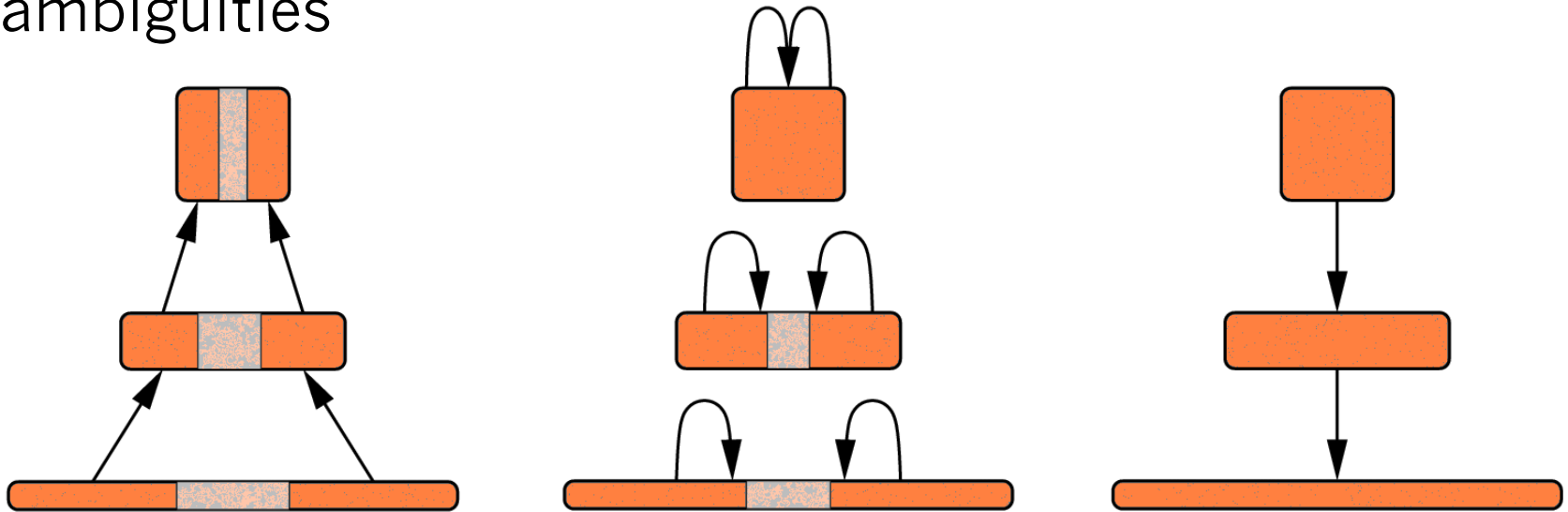
Neural Abstraction Pyramid

[Behnke, Rojas, IJCNN 1998]
[Behnke, LNCS 2766, 2003]



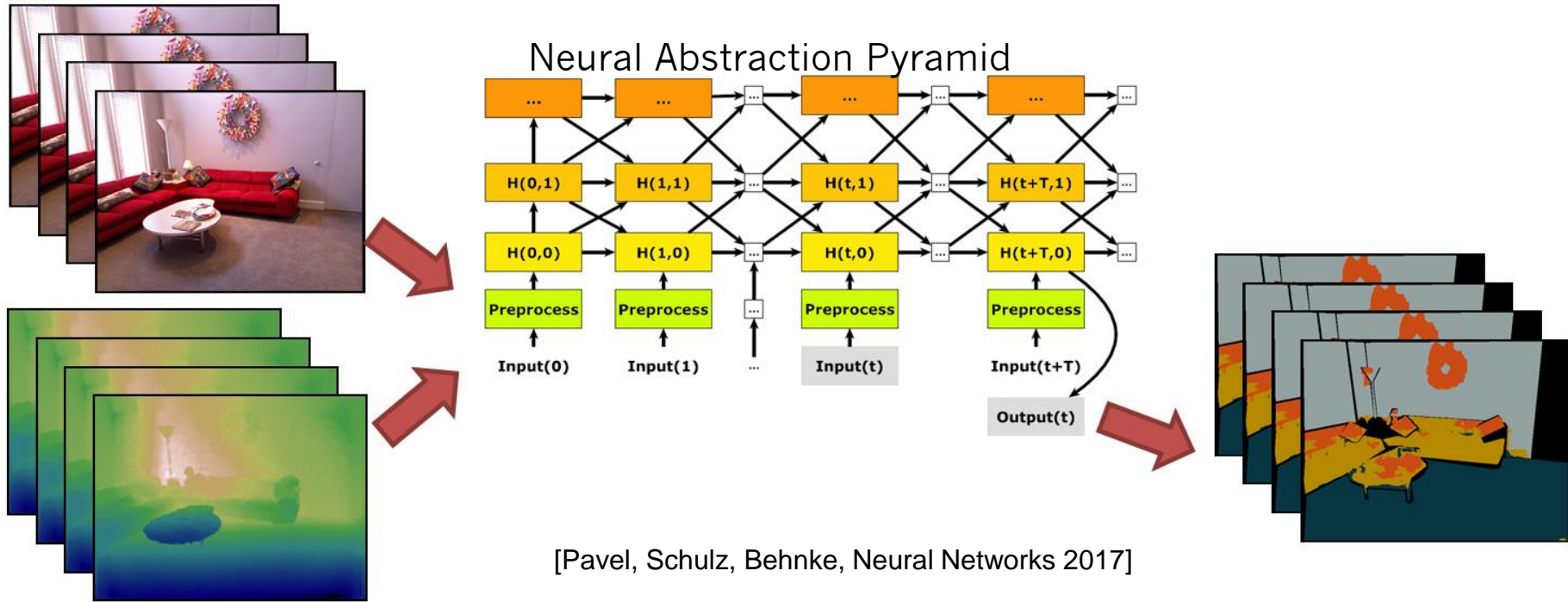
Iterative Image Interpretation

- Interpret most obvious parts first
- Use partial interpretation as context to resolve local ambiguities



Neural Abstraction Pyramid for RGB-D Video Object-class Segmentation

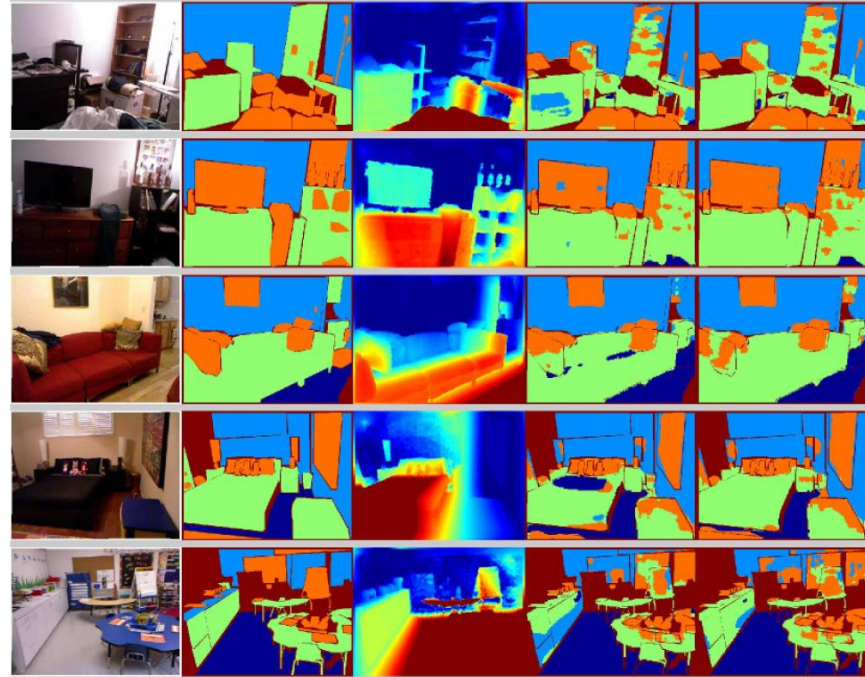
- Recursive computation is efficient for temporal integration



[Pavel, Schulz, Behnke, Neural Networks 2017]

Geometric and Semantic Features for RGB-D Object-class Segmentation

- New **geometric** feature: distance from wall
- **Semantic** features pretrained from ImageNet
- Both help significantly



[Husain et al. RA-L 2017]

RGB

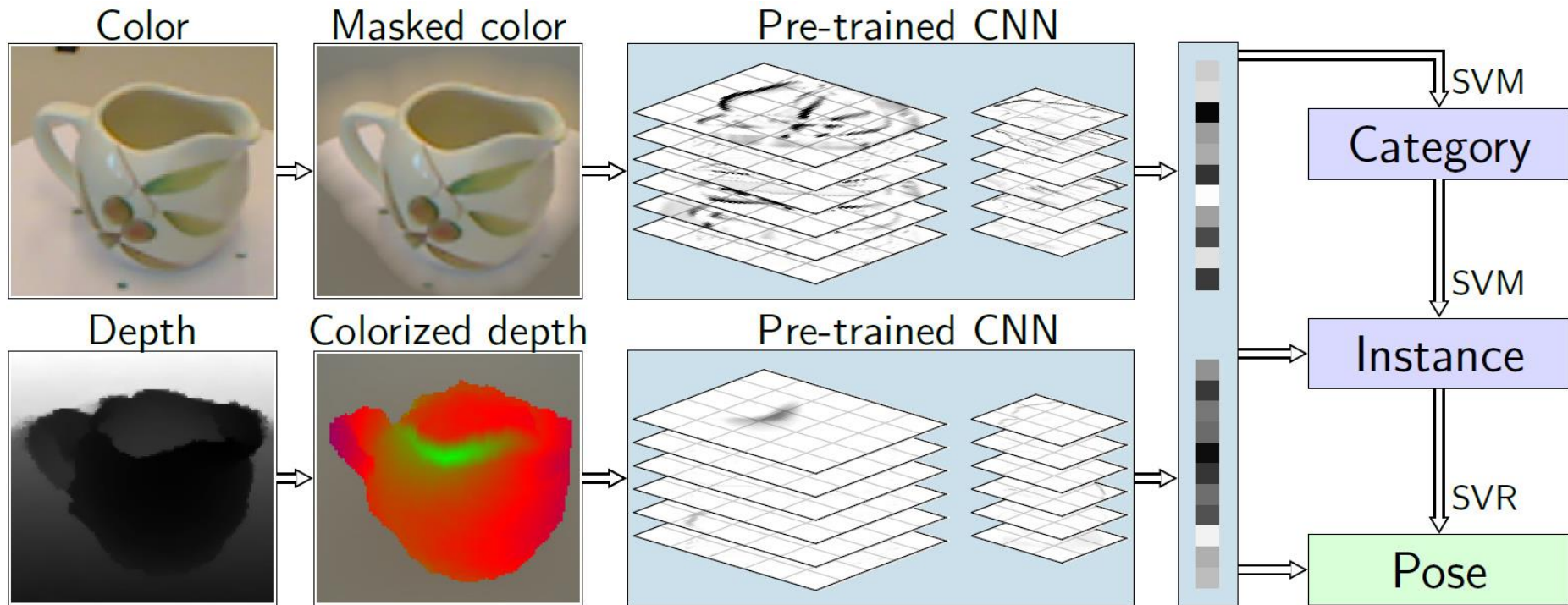
Truth

DistWall

OutWO

OutWithDistWall

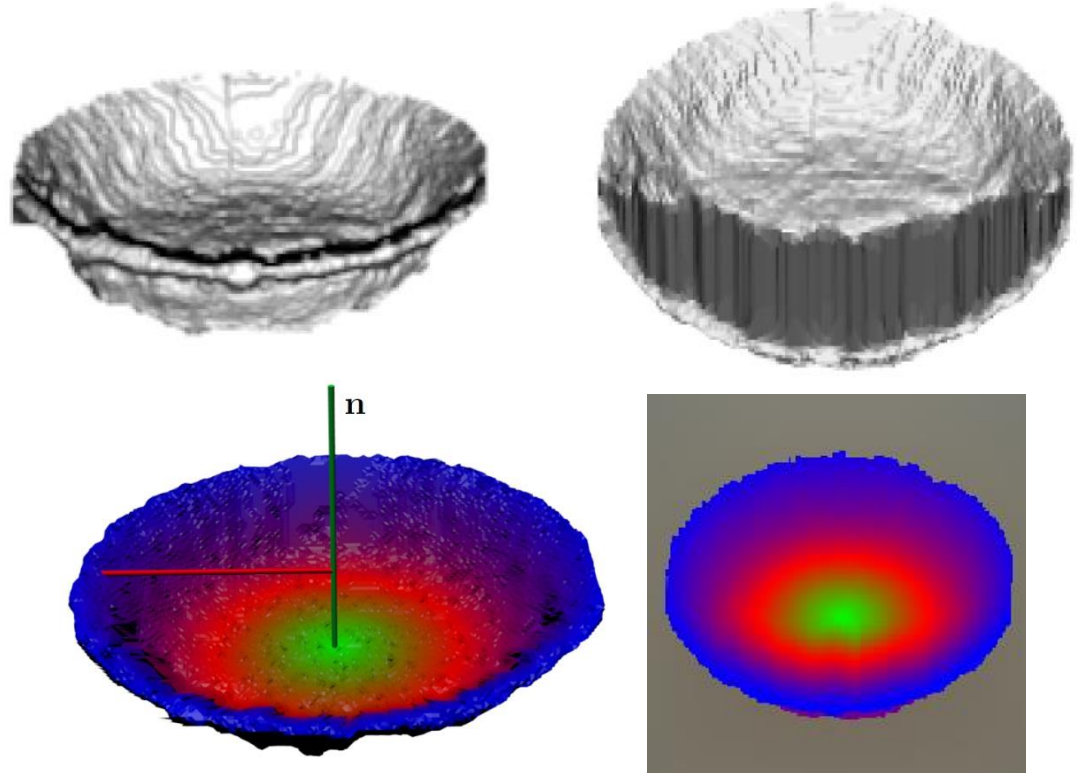
RGB-D Object Recognition and Pose Estimation



[Schwarz, Schulz, Behnke, ICRA2015]

Canonical View, Colorization

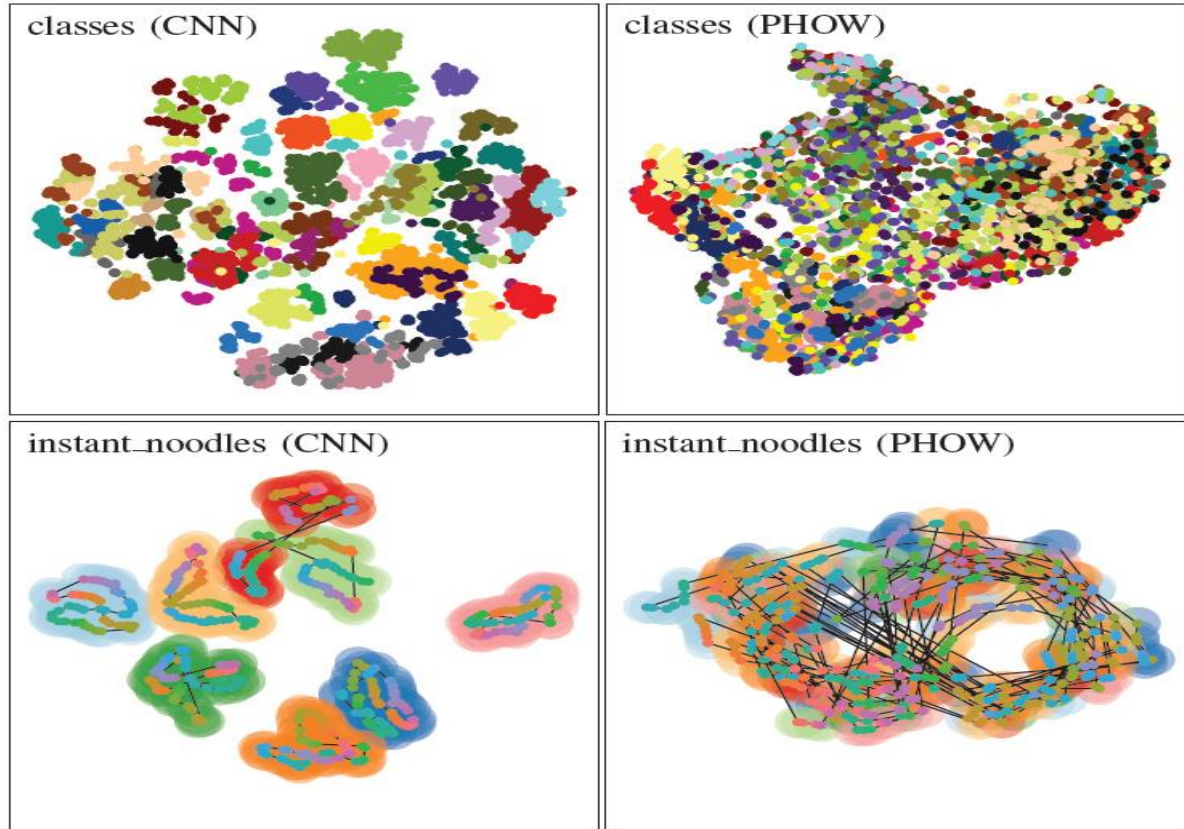
- Objects viewed from different elevation
- Render canonical view
- Colorization based on distance from center vertical



[Schwarz, Schulz, Behnke, ICRA2015]

Pretrained Features Disentangle Data

- t-SNE embedding



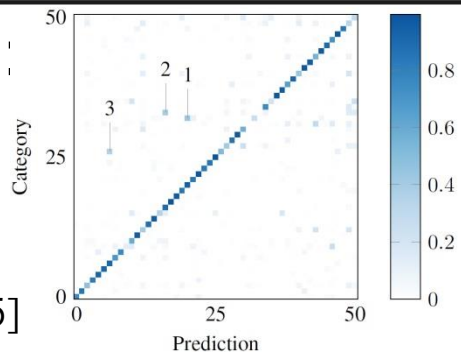
[Schwarz, Schulz,
Behnke ICRA2015]

Recognition Accuracy

- Improved both category and instance recognition

Method	Category Accuracy (%)		Instance Accuracy (%)	
	RGB	RGB-D	RGB	RGB-D
Lai <i>et al.</i> [1]	74.3 ± 3.3	81.9 ± 2.8	59.3	73.9
Bo <i>et al.</i> [2]	82.4 ± 3.1	87.5 ± 2.9	92.1	92.8
PHOW[3]	80.2 ± 1.8	—	62.8	—
Ours	83.1 ± 2.0	88.3 ± 1.5	92.0	94.1
Ours	83.1 ± 2.0	89.4 ± 1.3	92.0	94.1

- Confusion:



[Schwarz, Schulz,
Behnke ICRA2015]

1: pitcher / coffe mug

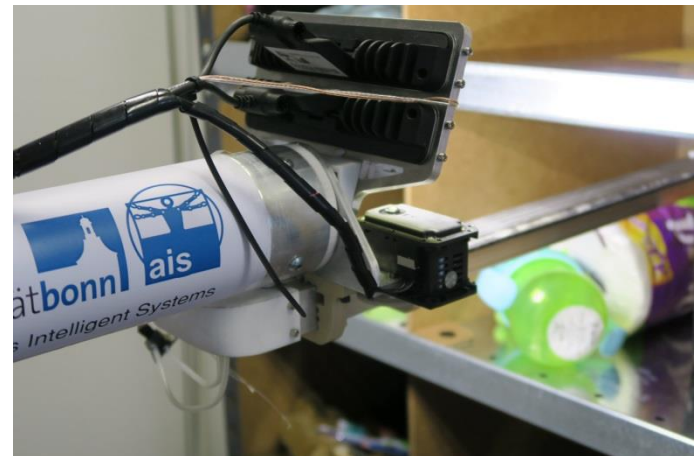


2: peach / sponge



Amazon Picking Challenge

- Large variety of objects
- Unordered in shelf or tote
- Picking and stowing tasks



[Schwarz et al. ICRA 2017]

Deep Learning Semantic Segmentation

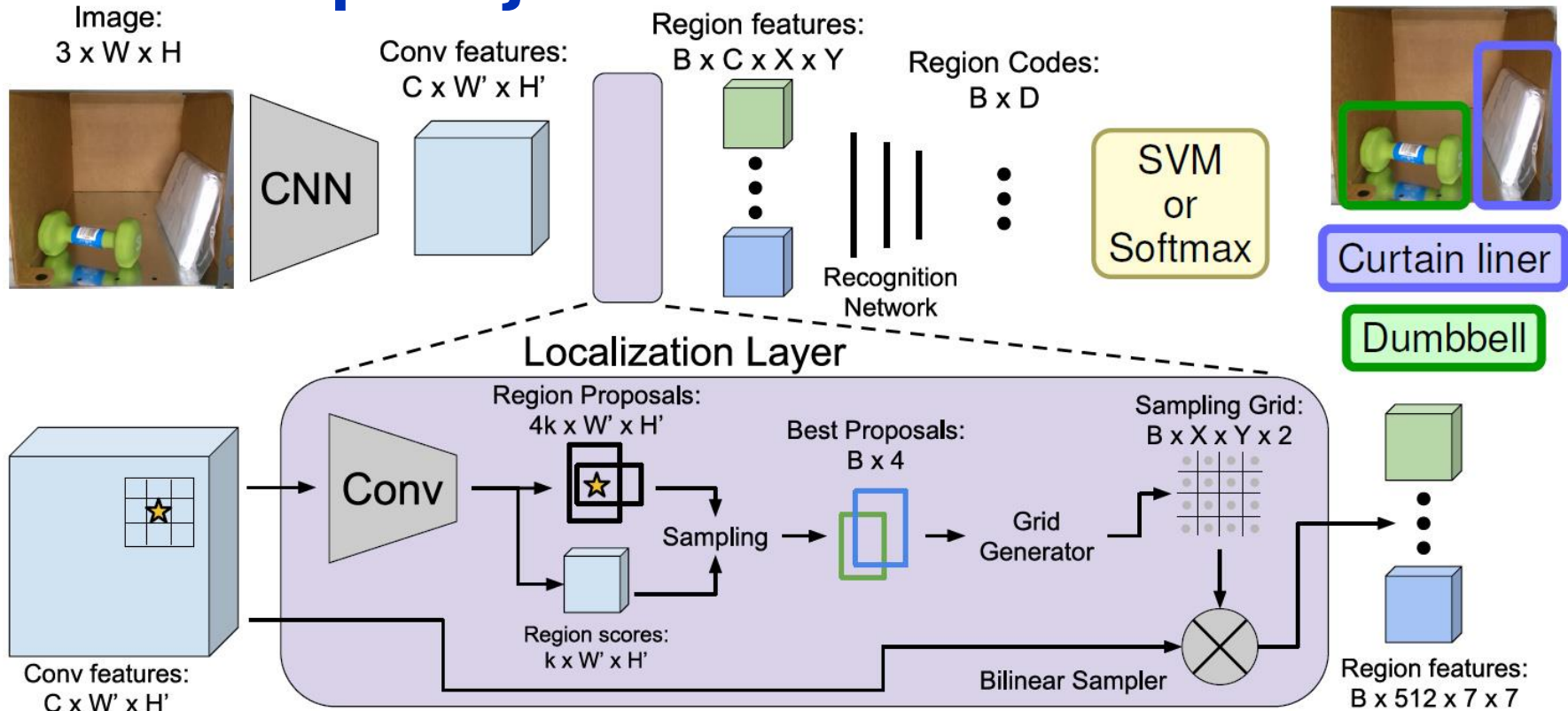
- Adapted from our segmentation of indoor scenes [Husain et al. RA-L 2016]



[Schwarz et al. ICRA 2017]



DenseCap Object Detection

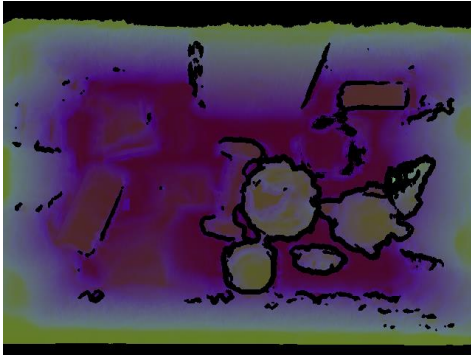
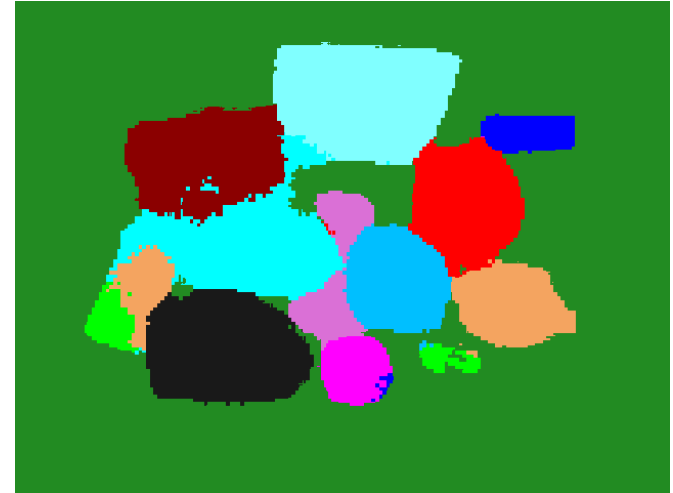
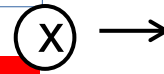
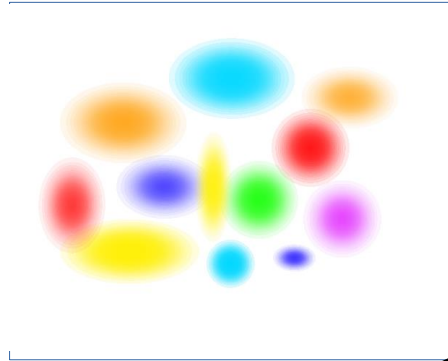


[Schwarz et al. ICRA 2017]

[Johnson et al. CVPR 2016]

Combined Detection and Segmentation

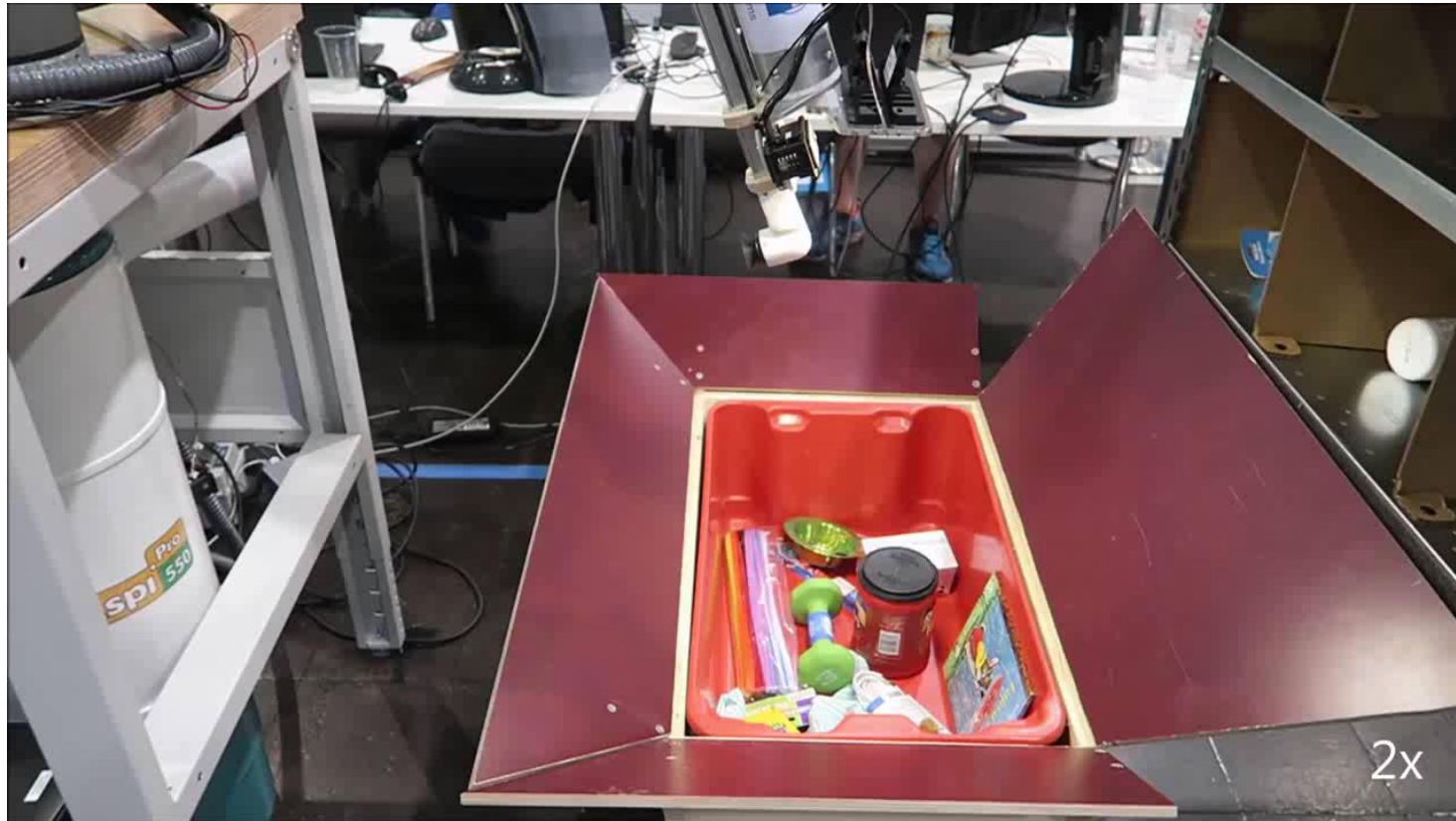
Detection



Segmentation

[Schwarz et al. IJRR 2017]

Stowing



Picking



4x

NimbRo Picking APC 2016 Results



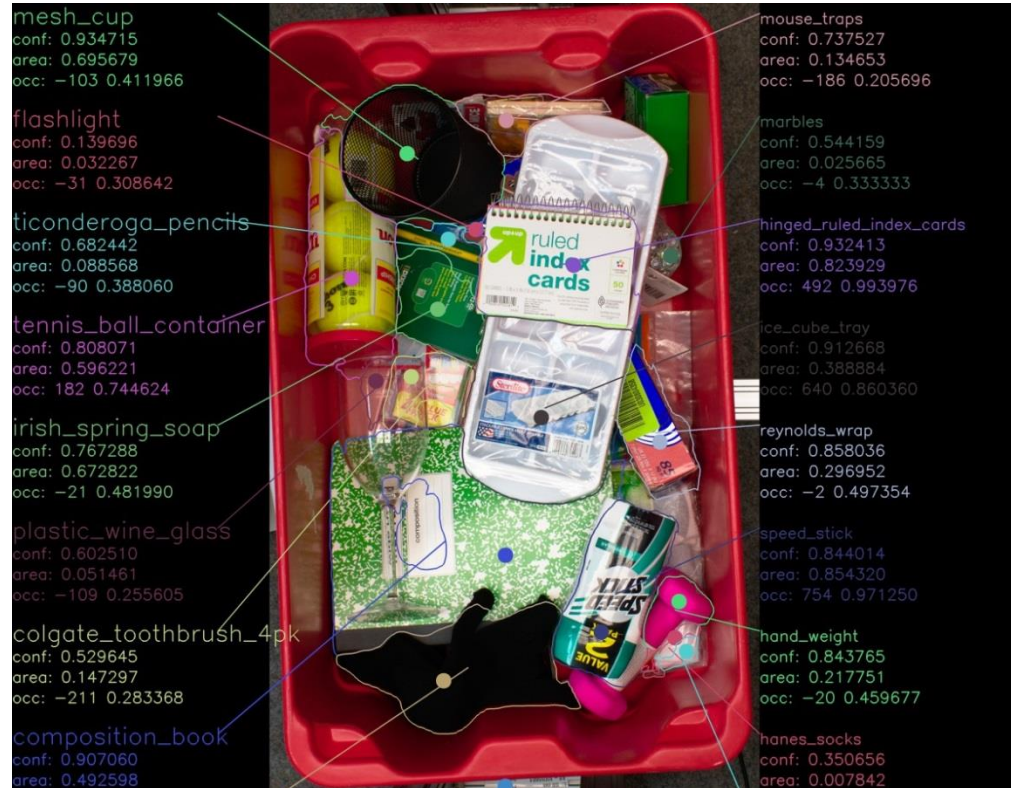
- 2nd Place Stowing (186 points)
- 3rd Place Picking (97 points)



[Schwarz et al. IJRR 2017]

Amazon Robotics Challenge 2017

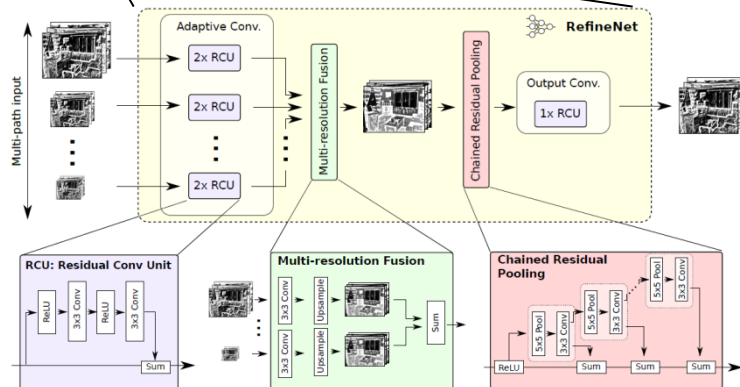
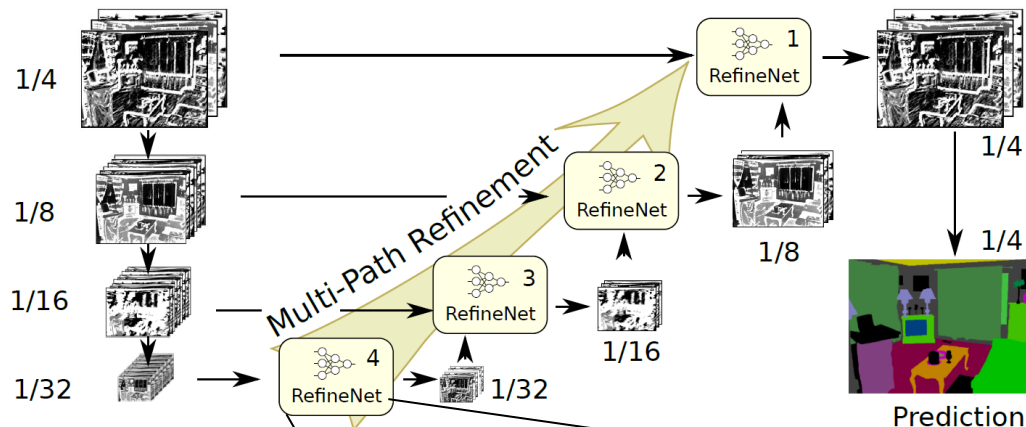
- Quick learning of novel objects
- Training with rendered scenes



RefineNet

- Increase resolution by using features from the higher resolution
- Coarse-to-fine semantic segmentation

[Lin et al. CVPR 2017]



Object Capture and Scene Rendering

- Turn table + DLSR



Rendered scenes



ARC 2017 Perception Example



bronze_wire_cup
conf: 0.749401

irish_spring_soap
conf: 0.811500

playing_cards
conf: 0.813761

w_aquarium_gravel
conf: 0.891001

crayons
conf: 0.422604

reynolds_wrap
conf: 0.836467

paper_towels
conf: 0.903645

white_facecloth
conf: 0.895212

hand_weight
conf: 0.928119

robots_everywhere
conf: 0.930464



mouse_traps
conf: 0.921731

windex
conf: 0.861246

q-tips_500
conf: 0.475015

fiskars_scissors
conf: 0.831069

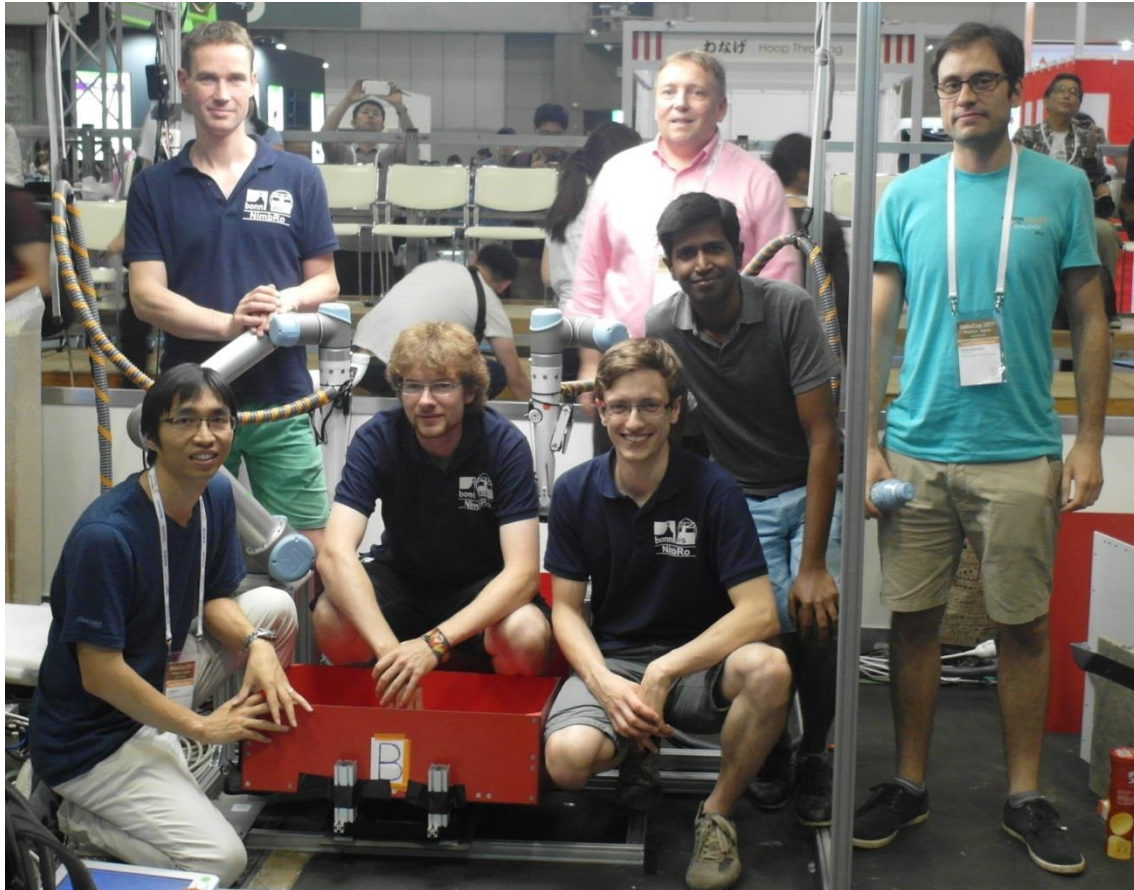
ice_cube_tray
conf: 0.976856

Amazon Robotics Challenge 2017 Final



NimbRo Picking 2017 Team

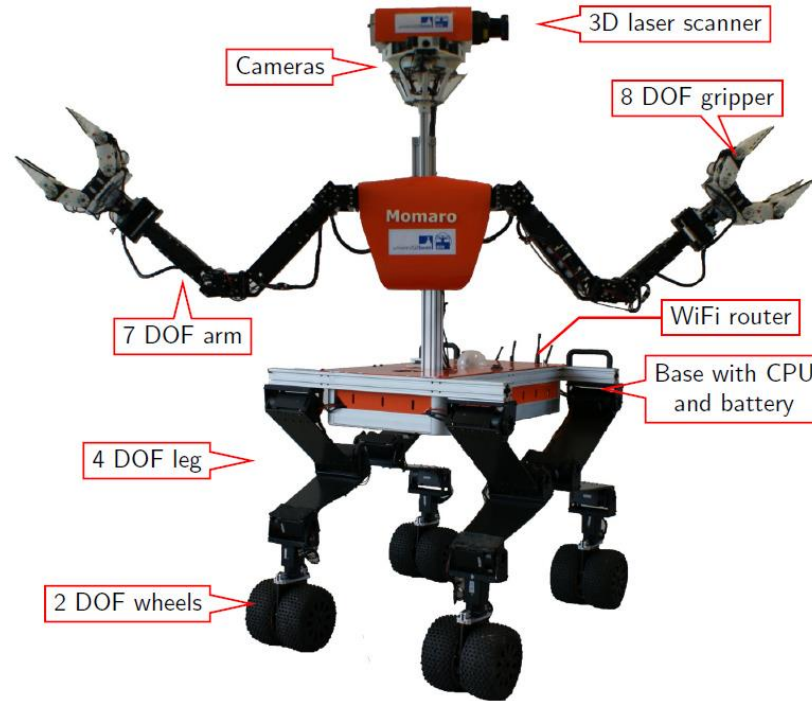
- 2nd place Pick
- 2nd place Stow-and-Pick Final



Mobiler Manipulations- Roboter Momaro



- Vier nachgiebige Beine mit lenkbaren Radpaaren
- Menschenähnlicher Oberkörper
- Sensorkopf
 - 3D-Laserscanner
 - IMU, Kameras



[Schwarz et al. Journal of Field Robotics 2017]

Führen eines Fahrzeugs



23:15:03 05/06/2015 UTC

36

4x

Ausstieg



23:16:59 05/06/2015 UTC

37

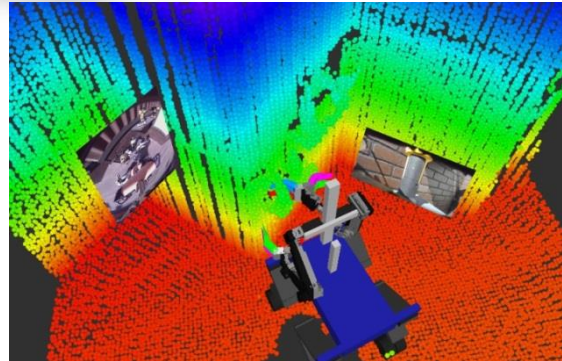
4x

Operator-Interface für die Manipulation

- 3D-Head-mounted Display



- 3D-Umgebungsmodell + Bilder



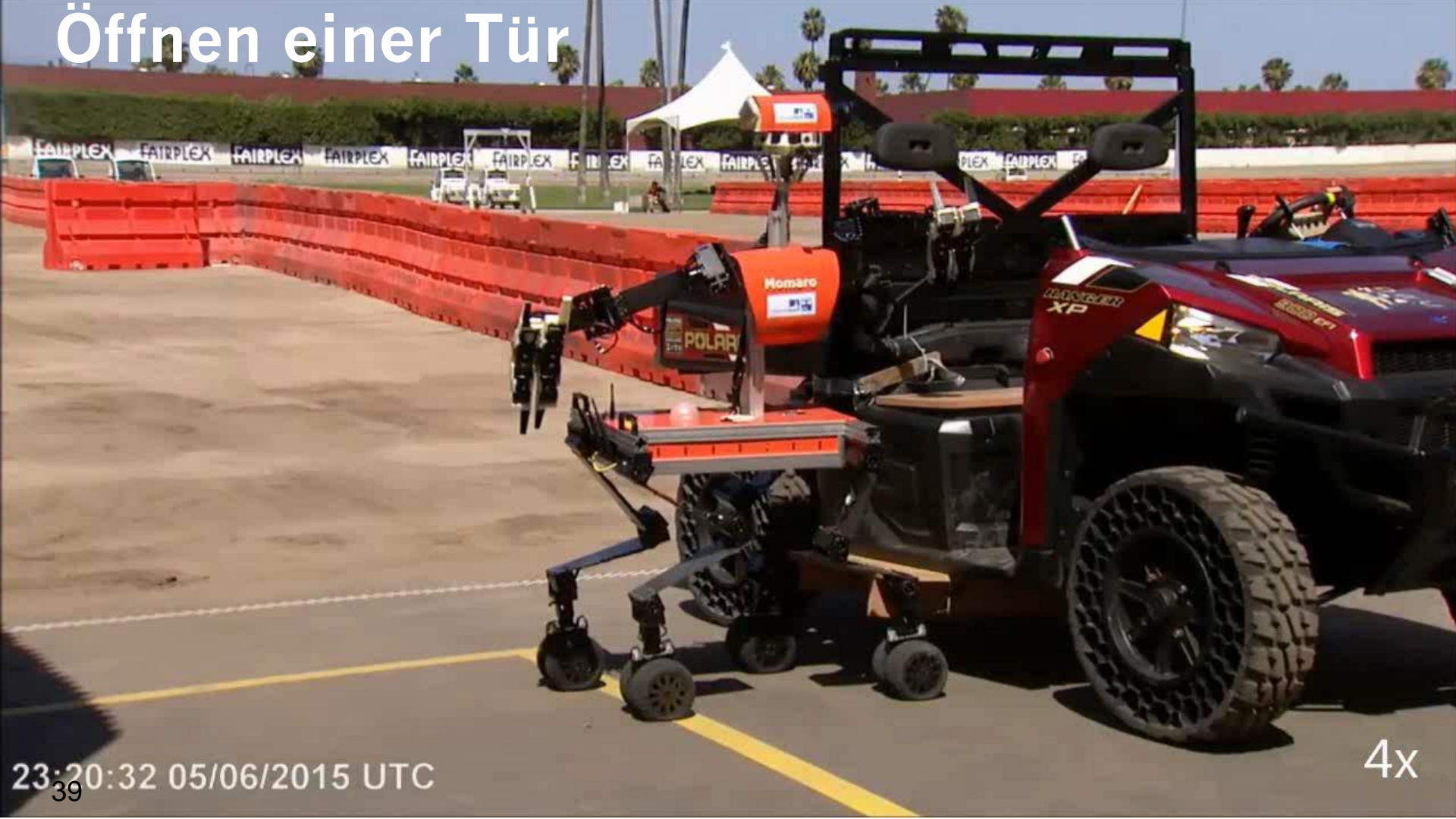
- 6D-Magnet-Tracker



[Rodehuts Kors et al., Humanoids 2015]



Öffnen einer Tür



23:20:32 05/06/2015 UTC

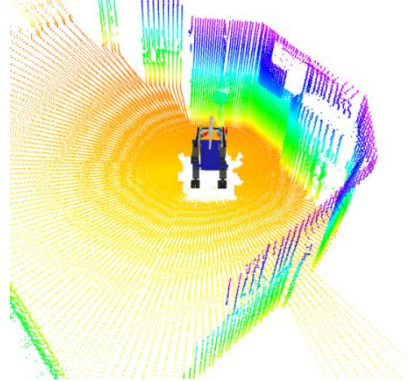
39

4x

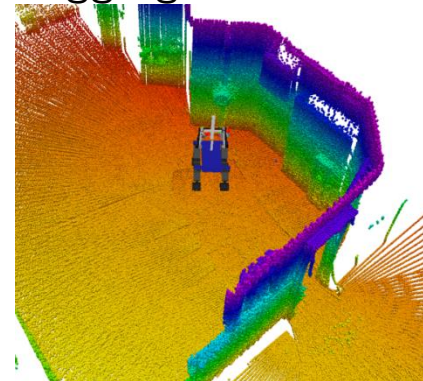
Lokale Multiresolutions-Surfel-Karten

- Registrierung und Aggregation von 3D-Laserscans
- Lokales Multiresolutionsgrid
- Surfel in den Zellen

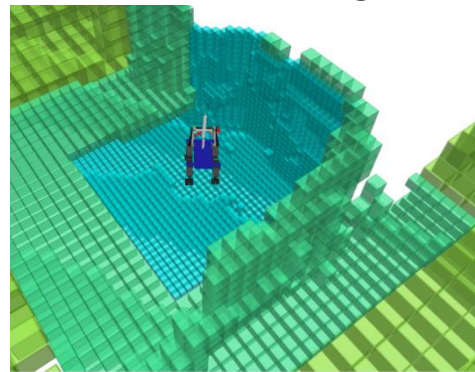
3D scan



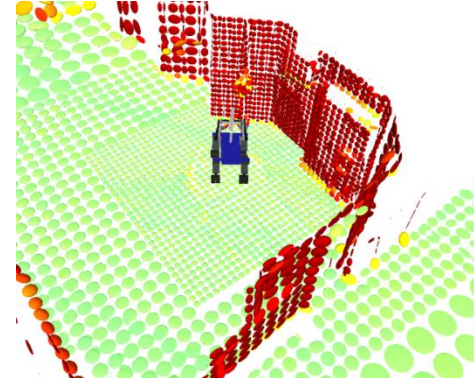
Aggregated scans



Multiresolution grid



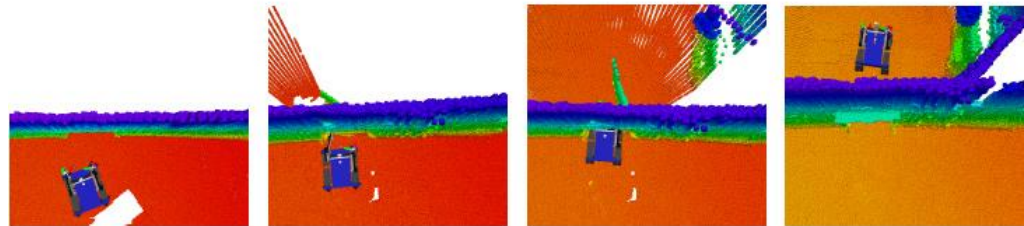
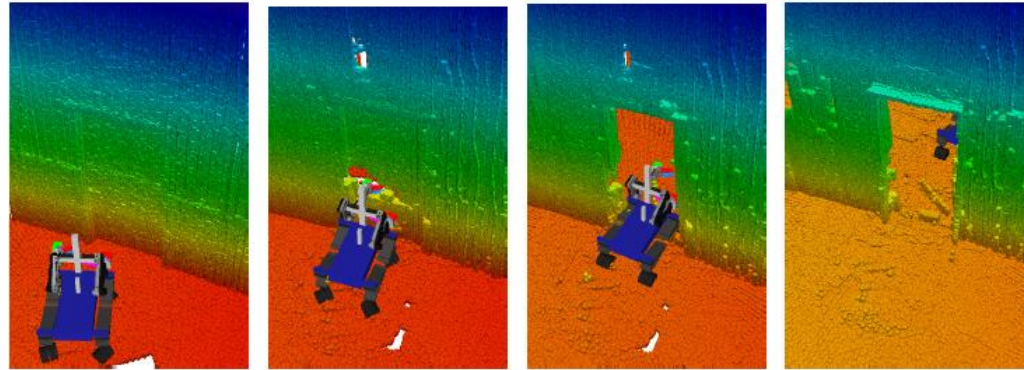
Surfels



[Droeschel et al., Robotics and Autonomous Systems 2017]

Filterung beweglicher Objekte

- Distanzmessungen sind auch Freimessungen
- Aktualisierung der Belegtheitschätzung in jeder Zelle



1 scan (5 s)

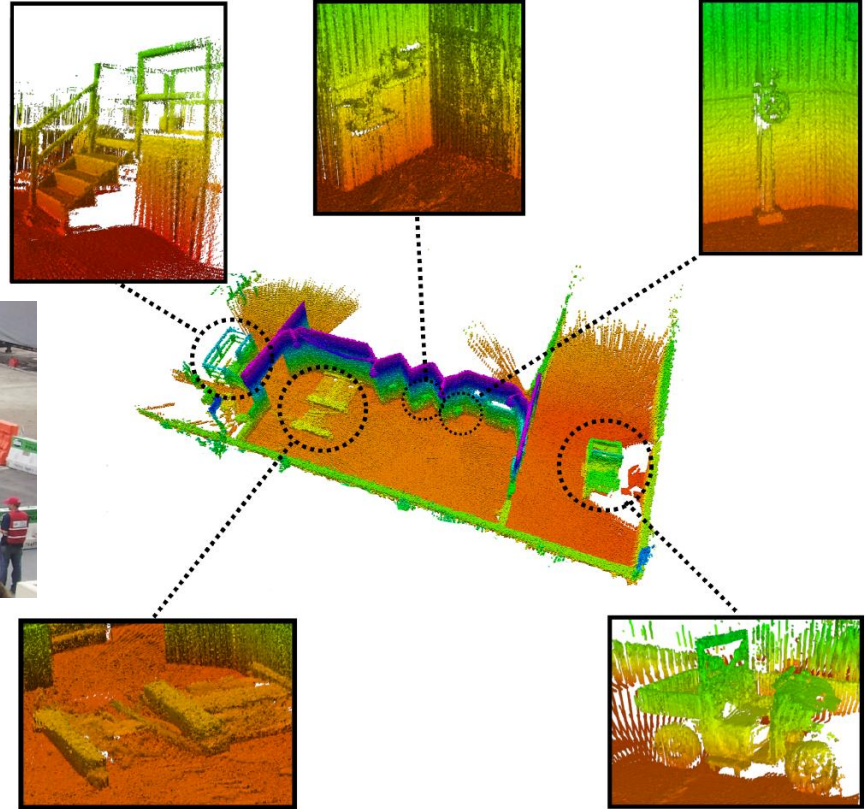
2 scans (10 s)

5 scans (25 s)

[Droeschel et al., Robotics and Autonomous Systems 2017]

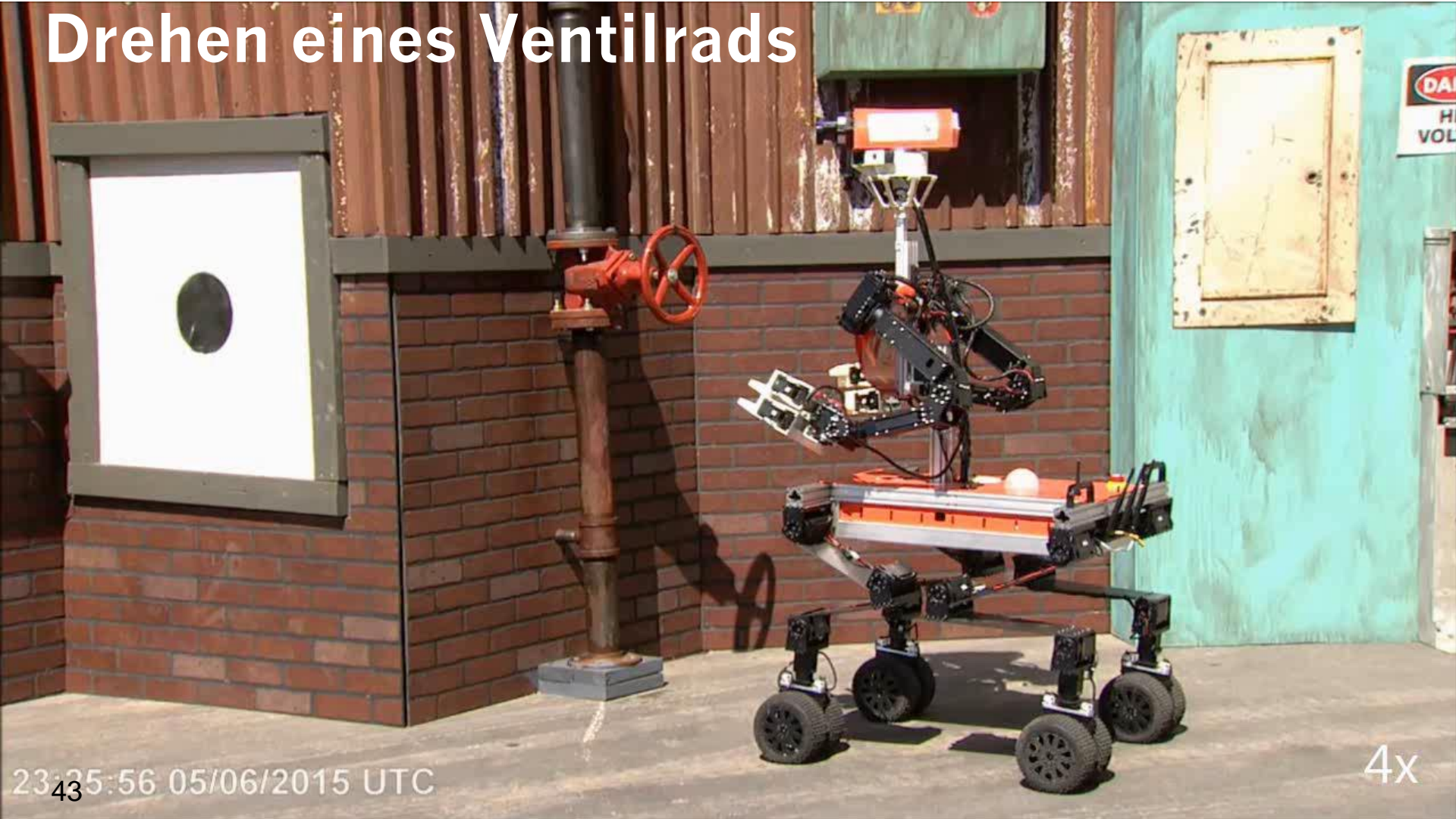
Allozentrische 3D-Kartierung

- Registrierung egozentrischer Karten durch Graphoptimierung



[Droeschel et al., Robotics and Autonomous Systems 2017]

Drehen eines Ventilrads



23:35:56 05/06/2015 UTC

43

4x

Umlegen eines Schalters



23:28:21 05/06/2015 UTC

44

4x

Umstecken



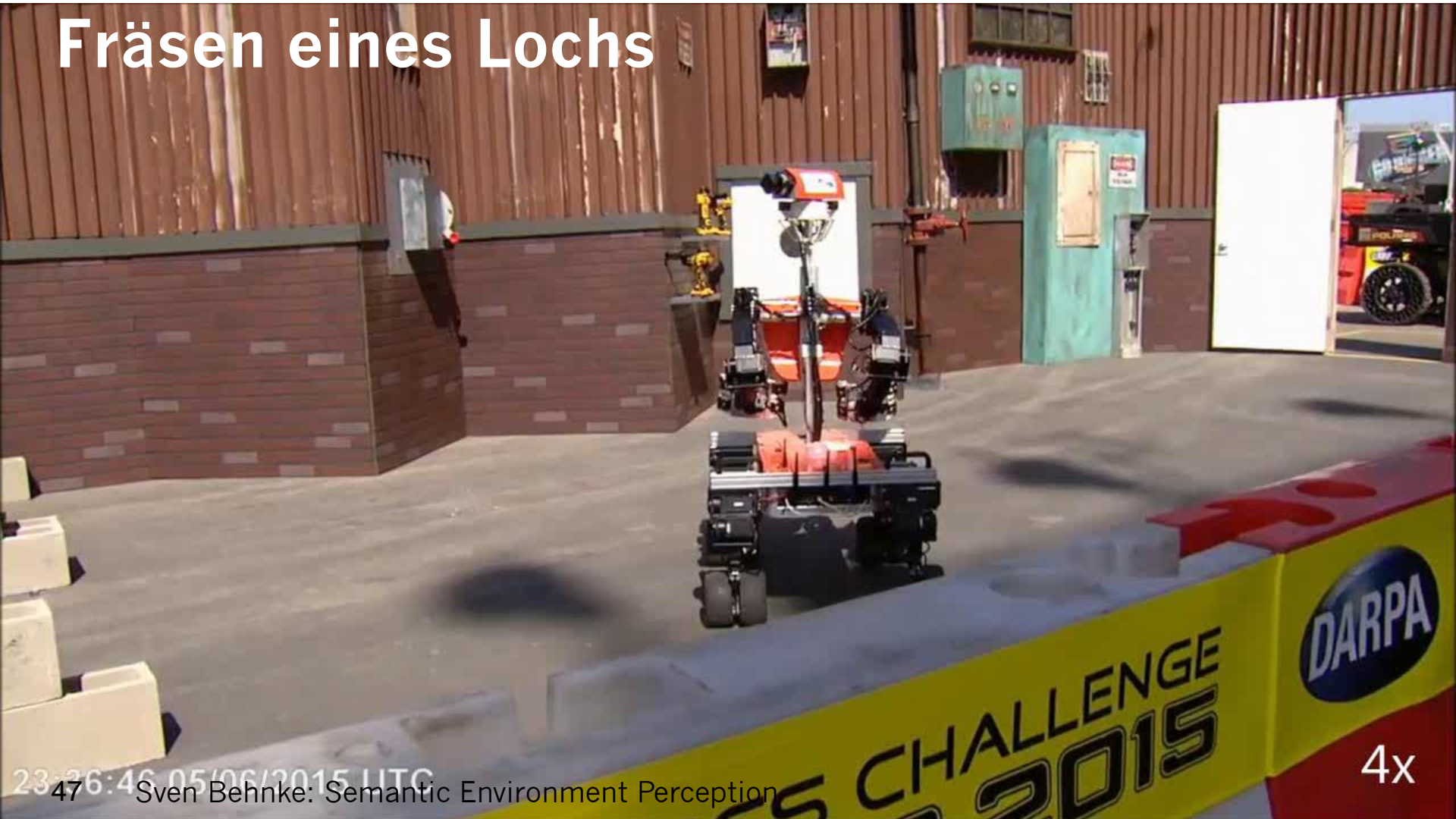
4X

02:33:20 07/06/2015 UTC

Überwindung von Hindernissen



Fräsen eines Lochs



23:26:46 05/06/2015 UTC

Team NimbRo Rescue

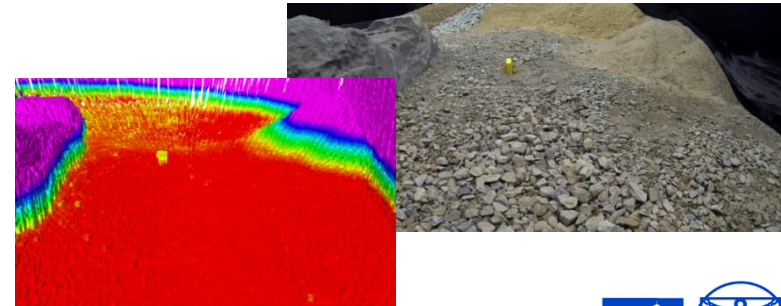
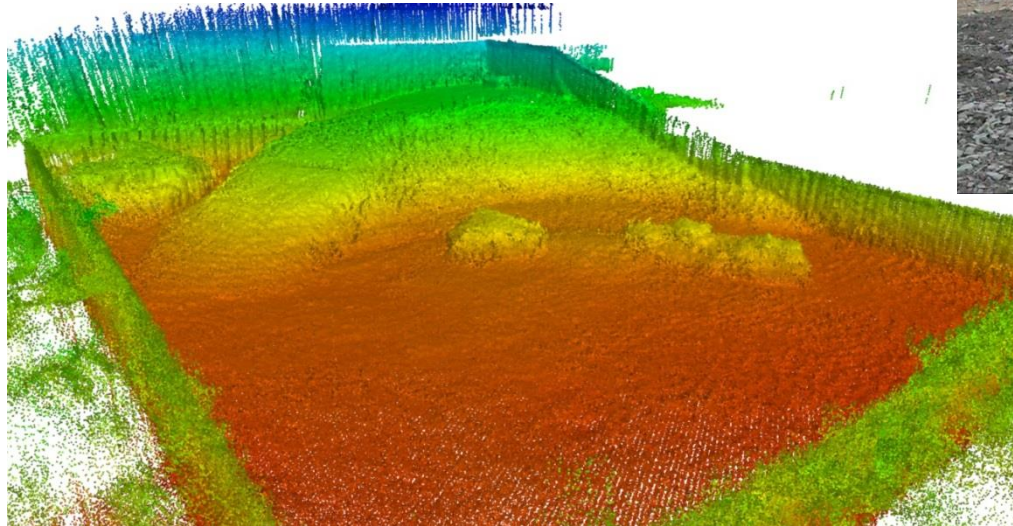


Bestes Europäisches Team (4. Platz)
Sieben von acht Aufgaben in 34 Min. gelöst

DLR SpaceBot Cup 2015

- Mobile Manipulation im Gelände

[Schwarz et al., Frontiers on Robotics and AI 2016]

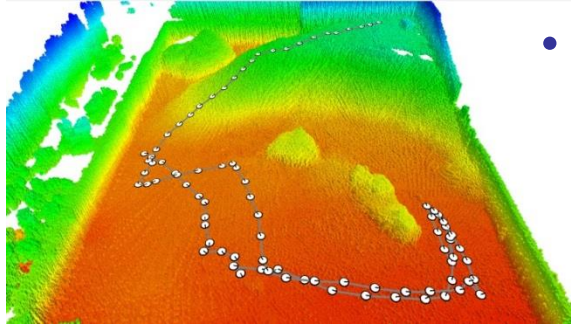


DLR SpaceBot Camp 2015

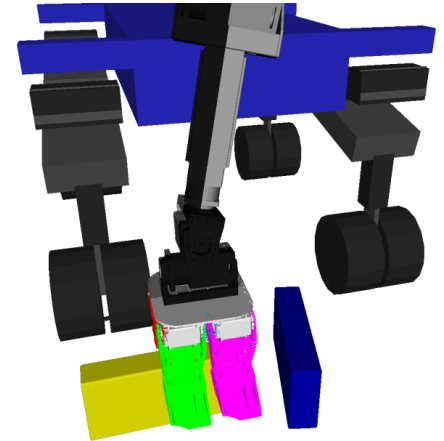
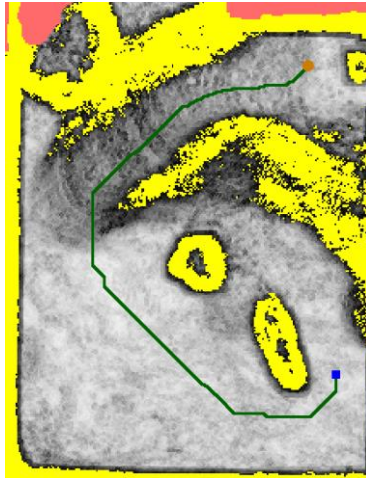
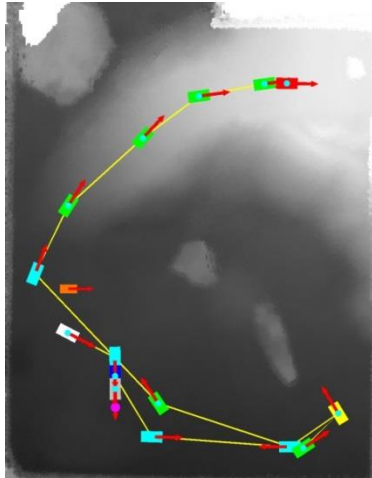
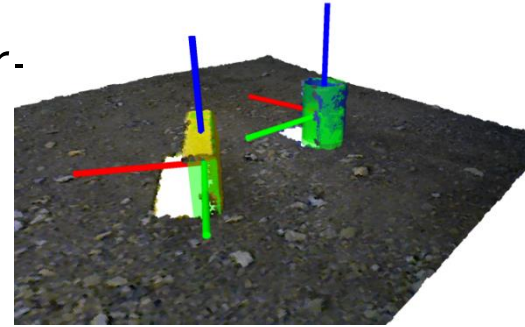


Autonome Missionsausführung

- 3D-Kartierung, Lokalisierung, Missions- und Navigationsplanung



- 3D-Objektwahrnehmung und Handhabung

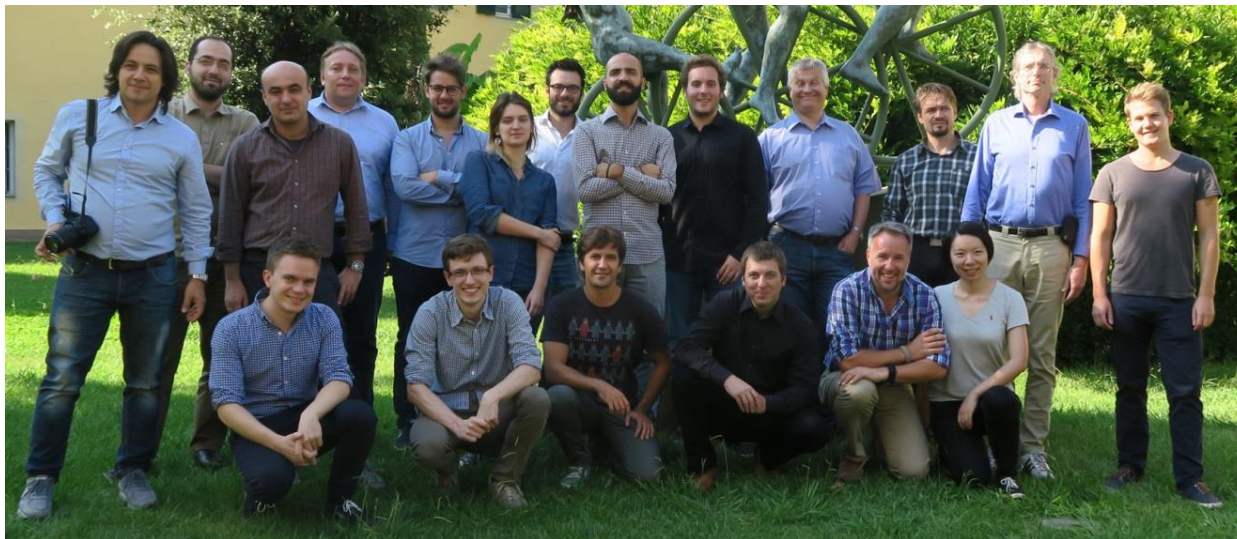


[Schwarz et al. Frontiers 2016]

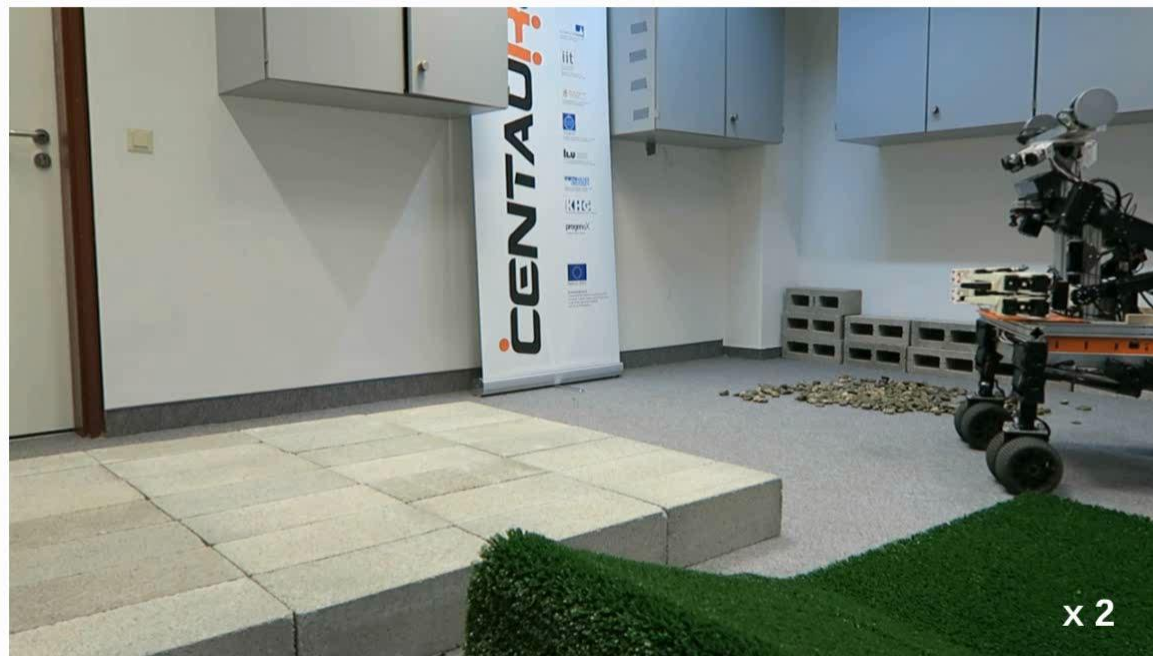
H2020 Project **CENTAURO**



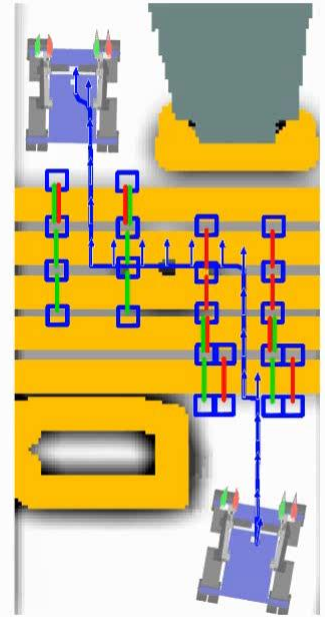
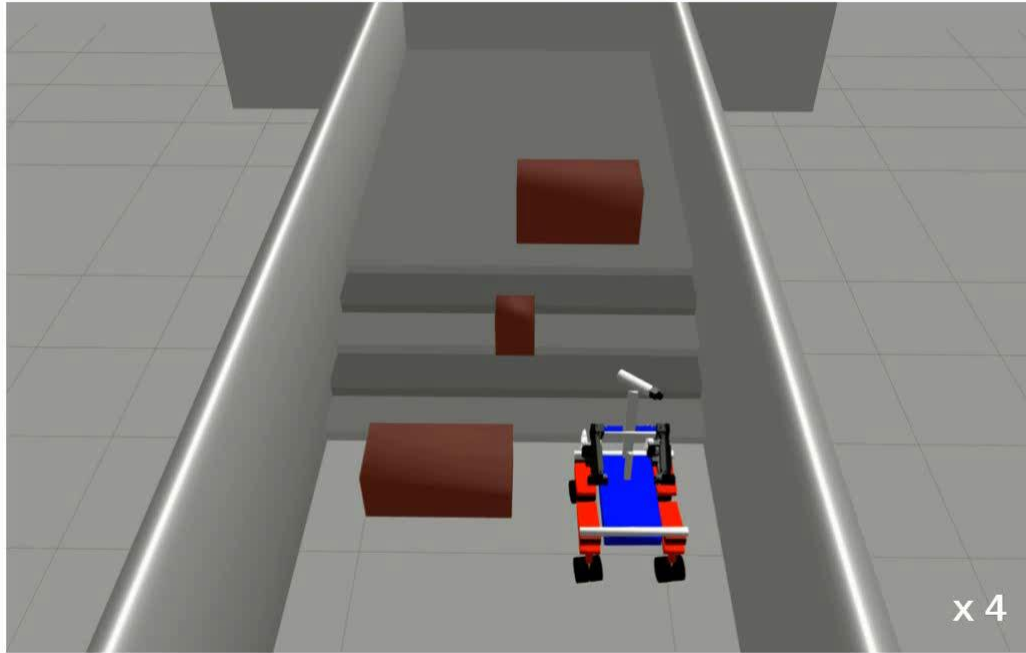
Robust Mobility and Dexterous Manipulation in Disaster Response by Fullbody Telepresence in a Centaur-like Robot



Expanding Abstract Steps to Detailed Motion Sequences

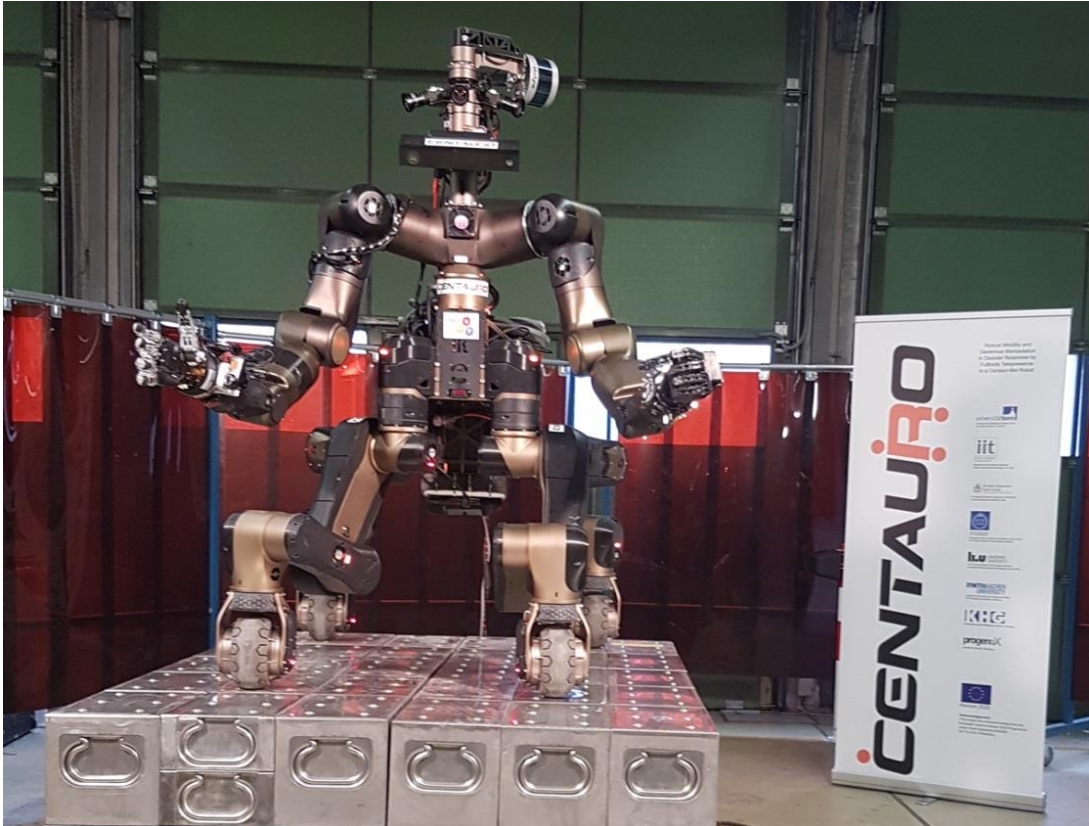


Planning for Challenging Scenarios



1st Centauro Robot

CENTAURO

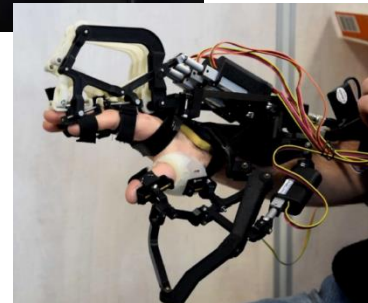


- Serial elastic actuators
- 42 main DoFs
- Schunk hand
- 3D laser
- RGB-D camera
- Color cameras
- Two GPU PCs

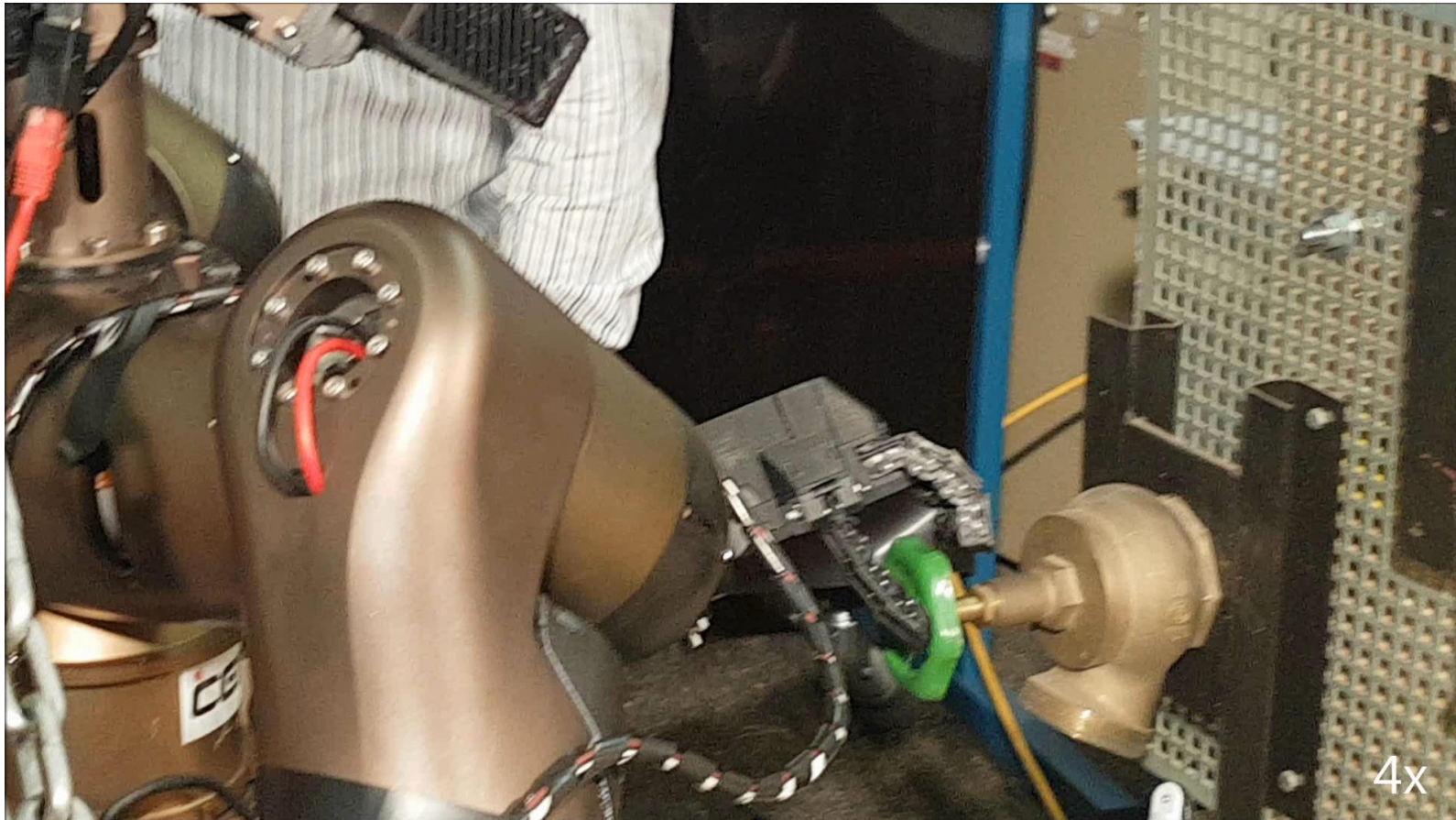
[Tsagarakis et al.,
IIT 2017]

Main Operator Telepresence Interface

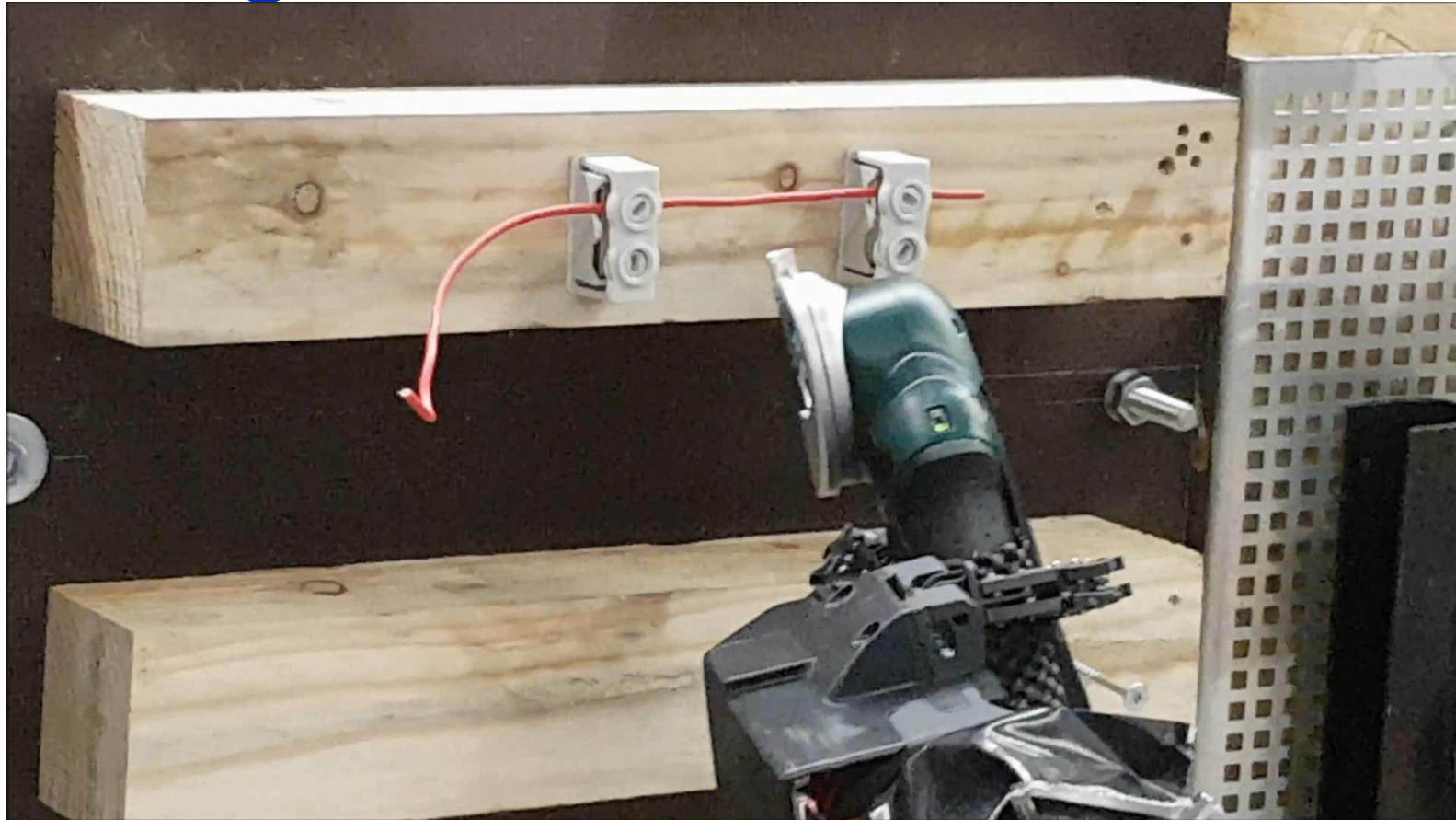
- Tendon-driven dual-arm exoskeleton
- Active wrist with differential tendon transmission
- Underactuated hand exoskeleton
- Head-mounted display
- Foot pedals



Turning a Valve



Cutting a Wire



Climbing over a Gap



Walking over a Step Field



Transfer of Manipulation Skills



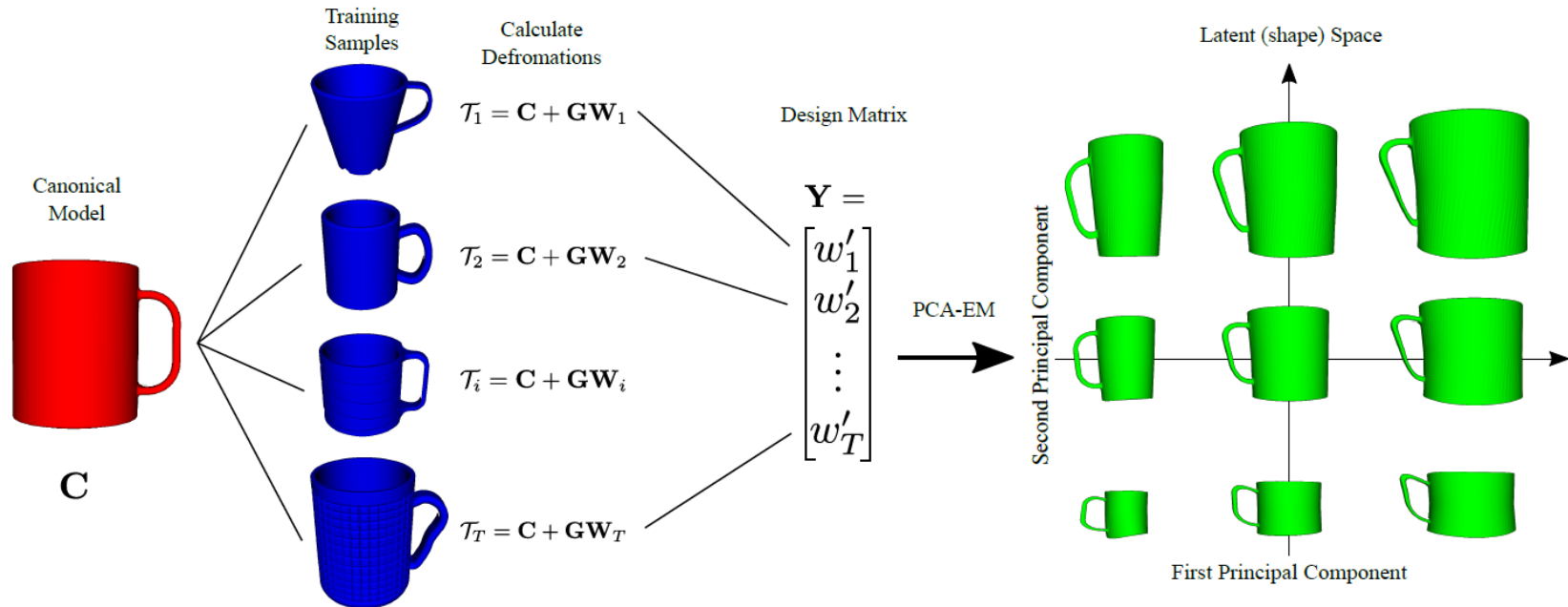
Knowledge
Transfer



[Rodriguez et al. ICRA 2018]

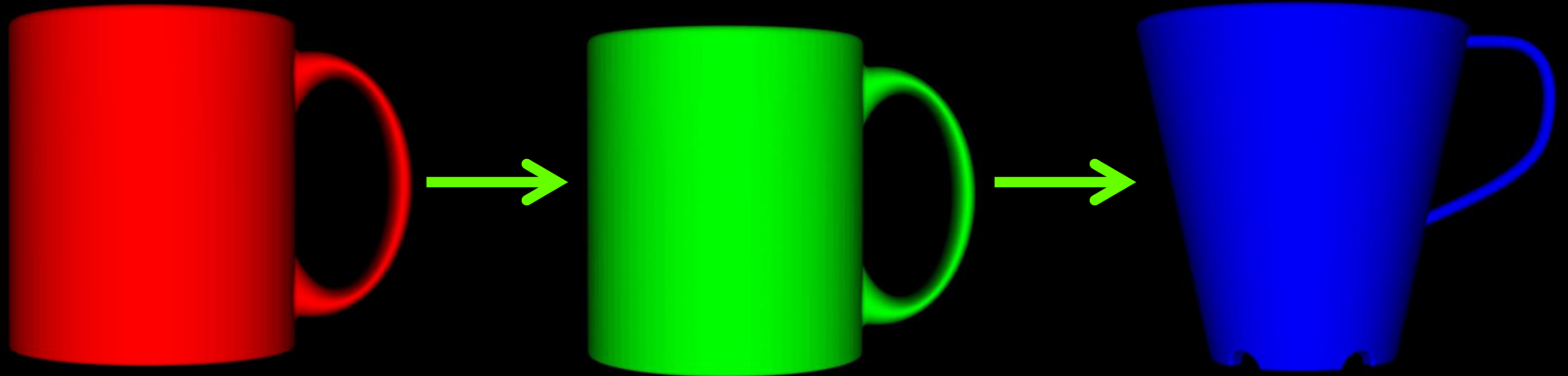
Learning a Latent Shape Space

- Non-rigid registration of instances and canonical model
- Principal component analysis of deformations



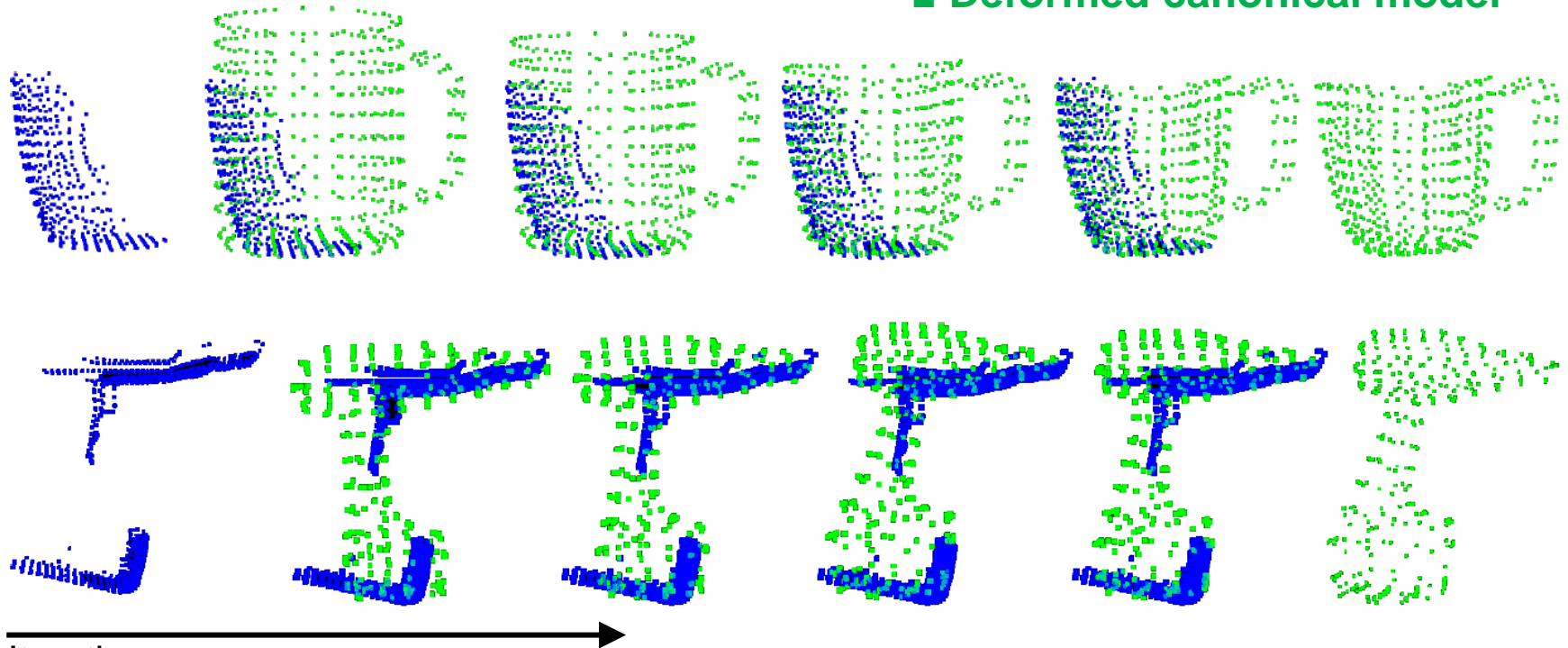
[Rodriguez et al. ICRA 2018]

Interpolation in Shape Space



Shape-aware Non-rigid Registration

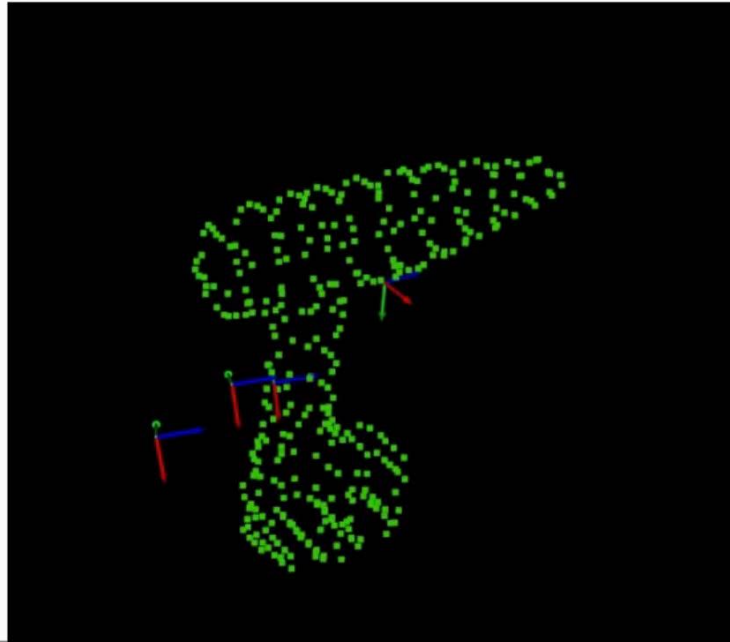
- Partial view of novel instance
- Deformed canonical model



[Rodriguez et al. ICRA 2018]

Transference of Grasping Skills

Warp grasping information



[Rodriguez et al. ICRA 2018]

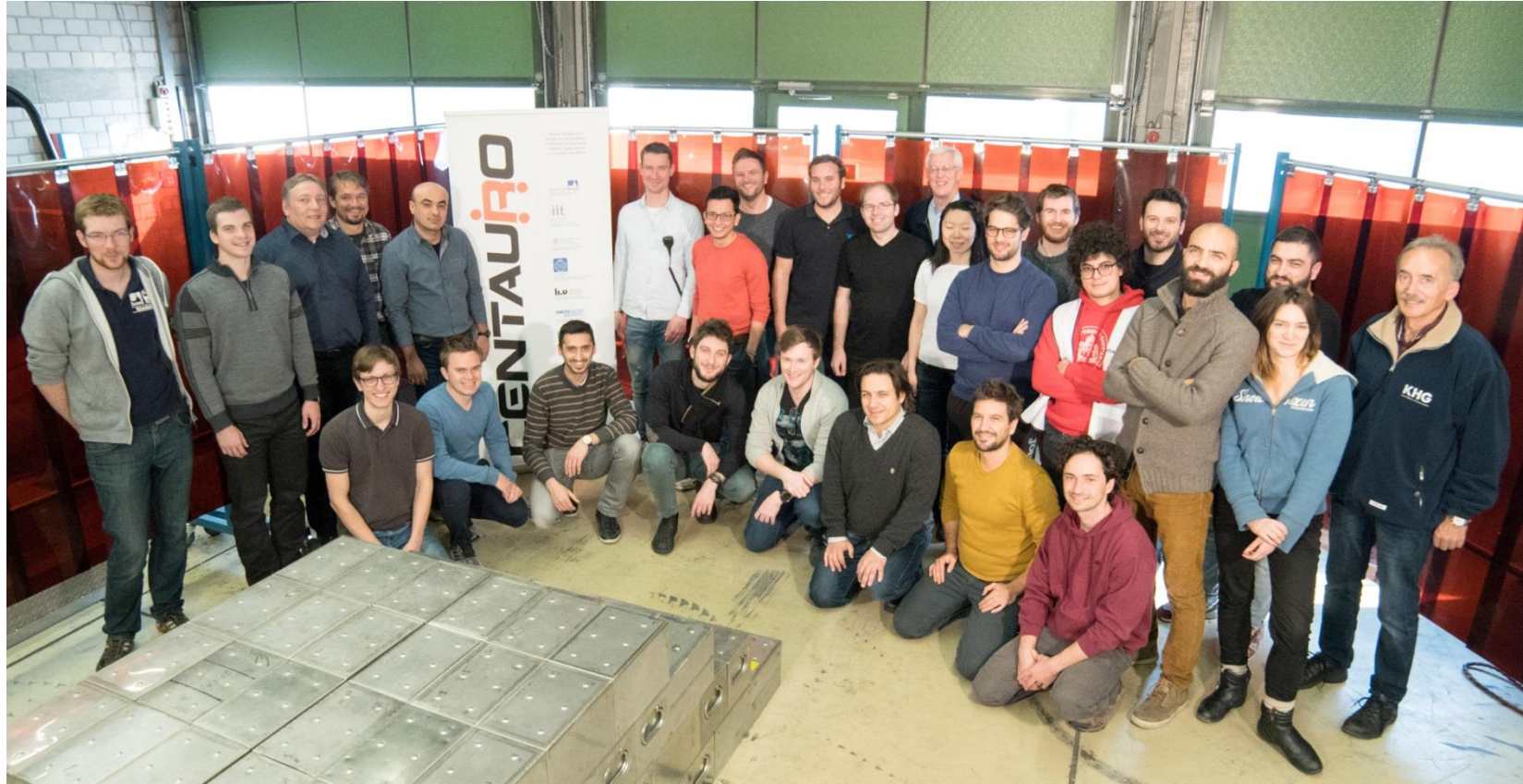
Grasping an Unknown Power Drill



Fastening a Screw

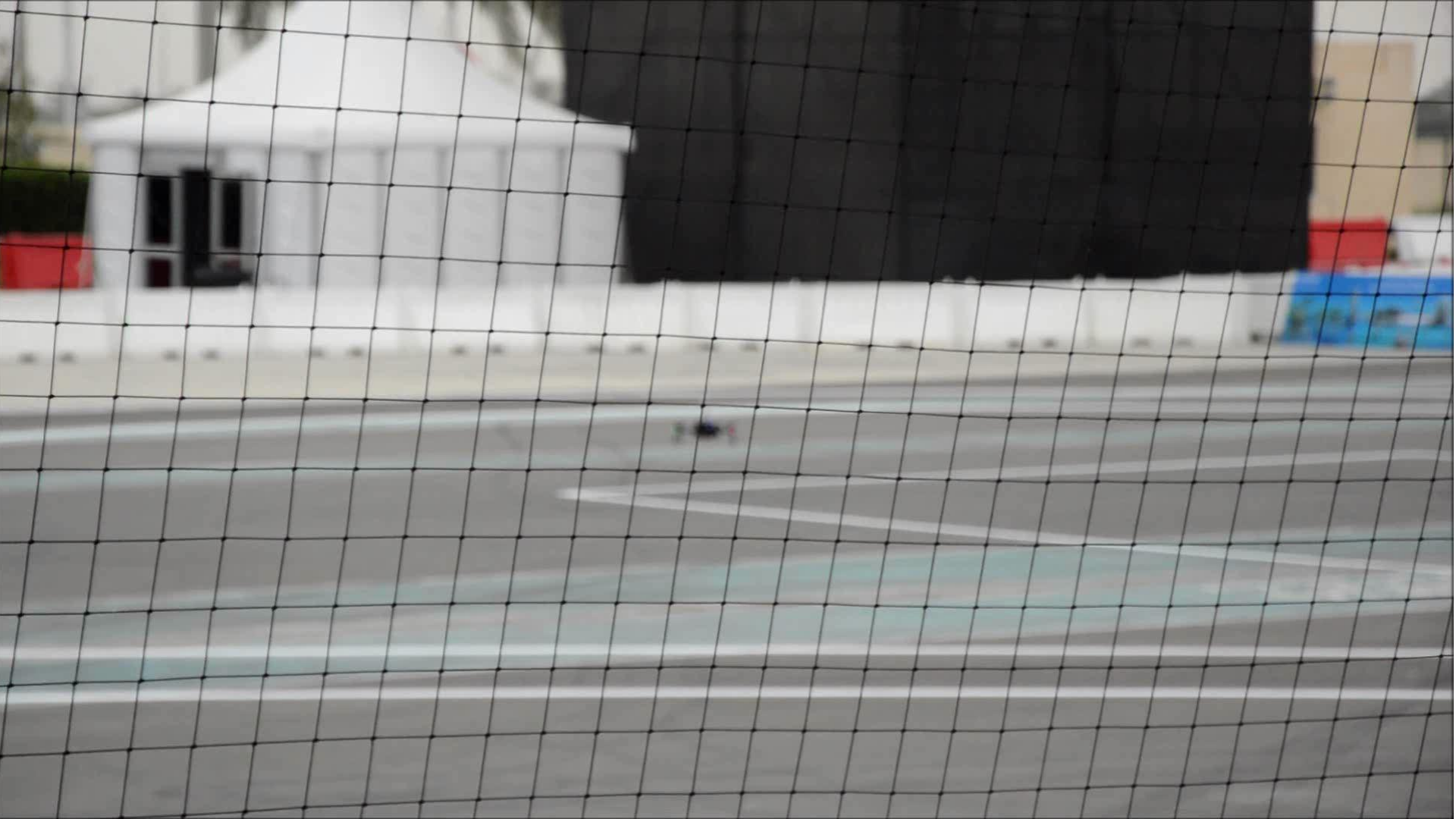


CENTAURO Team

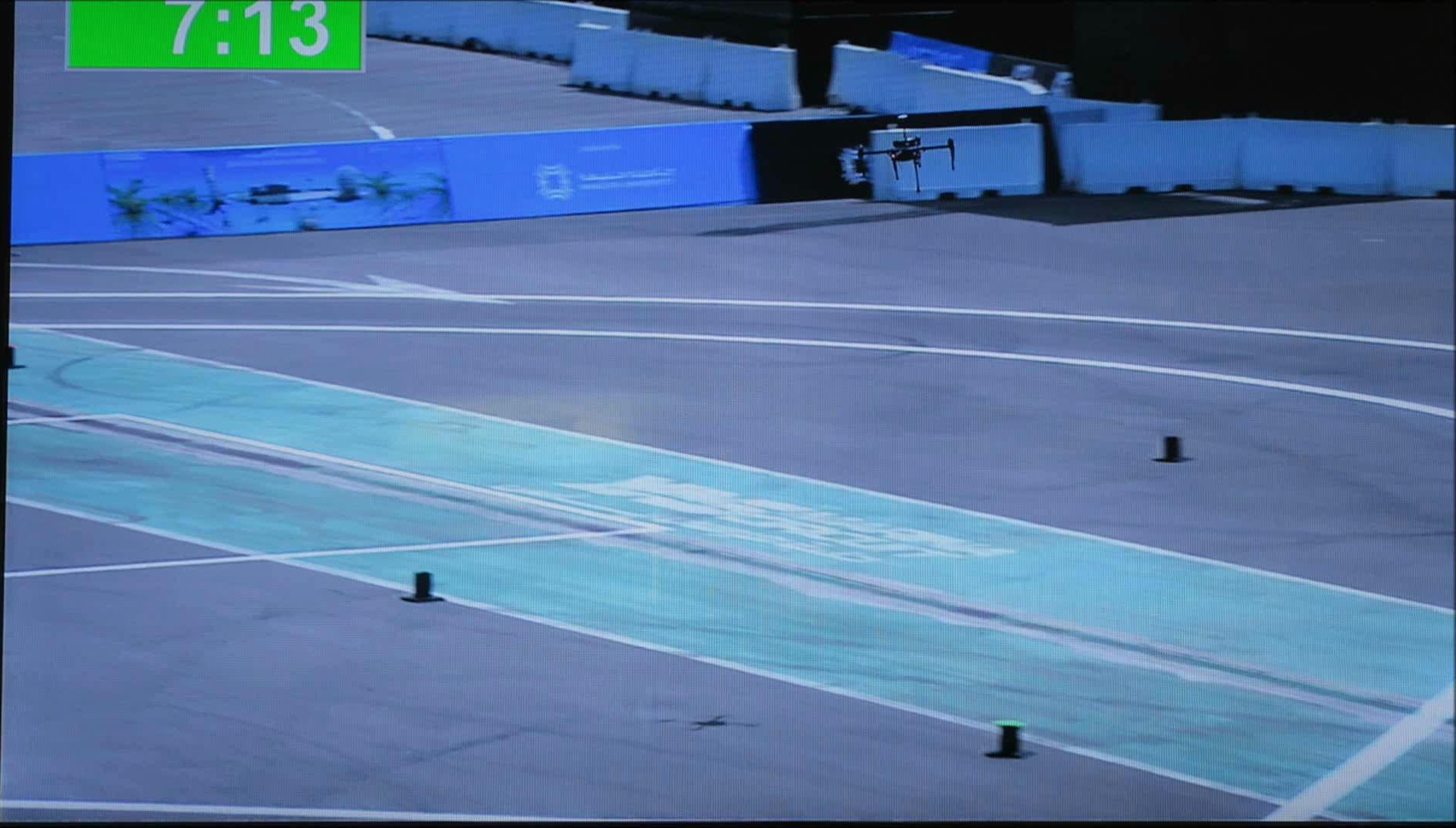


MBZIRC Challenge 2





7:13



MBZIRC Team NimbRo



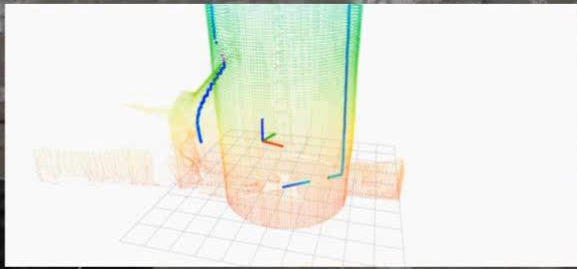
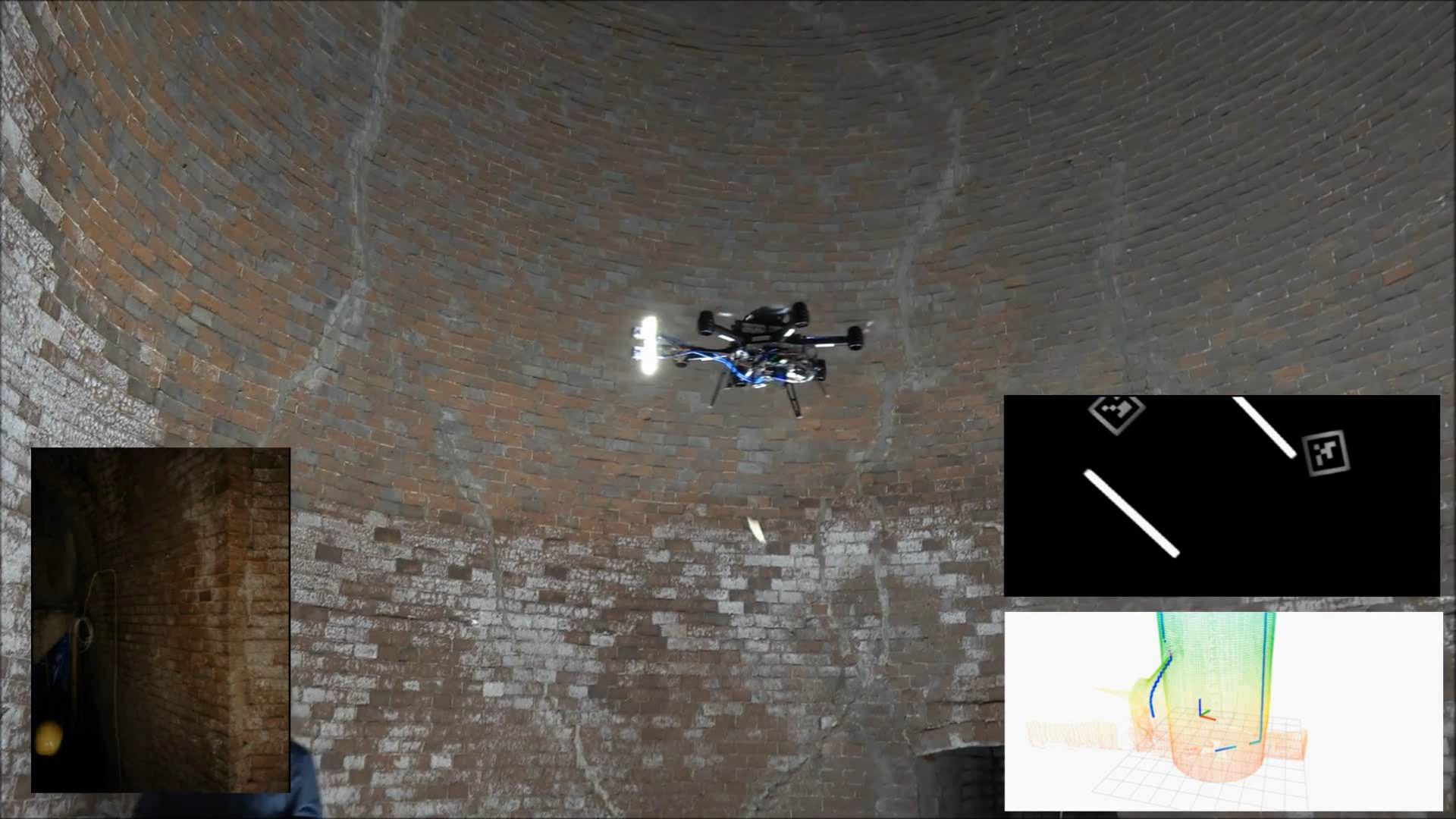
DJI Matrice 600 with Velodyne Puck



Autonomous Indoor Navigation



Fully Autonomous indoor flight without external tracking.



Zusammenfassung

- Beispiele für kognitive Roboter in komplexen Szenarien
 - Humanoide Fußballroboter
 - Serviceaufgaben im Haushalt
 - Griff in die Kiste
 - Menschenfeindliche Umgebungen
 - Flugroboter
- Herausforderungen beinhalten
 - 3D-Kartierung, semantische Szeneninterpretation
 - Hochdimensionale Bewegungsplanung, robuste Bewegungskontrolle
- Mögliche Lösungsansätze
 - Zusammenführen von Erfahrungen vieler Roboter
 - Kombination von menschlicher Intelligenz und Autonomie
 - Instrumentierte Umgebungen